

**ARTWORK
SPECIFICATION SHEET
&
TERMS & CONDITIONS**

ExCel London Invision
Management Office
K Warehouse
One Western Gateway
Royal Victoria Dock
London E16 1XL

Telephone: +44 (0)20 7069 4000

Facsimile: +44 (0)20 7069 4640

Email: advertising@excel-london.co.uk

Website: www.excel-londonadvertising.co.uk

Hall Entrances

Hall Entrance Rear Panel	7
Hall Entrance Rear Vinyl	7
Hall Entrance Side Panels (Pair)	7
Lower Entrance Back Panels (Pair)	7
Lower Entrance Front Panels (Pair)	8
Hall Entrance Totems	9
Hall Entrance Totem Banners	9

Pyramid

Pyramid Welcome Banner	10
Pyramid Shaped Banner	10

96-Sheet Posters

Boulevard 96-Sheet Poster	11
Boulevard Crop 96-Sheet Poster	11
External 96-Sheet Poster	11

48-Sheet Posters & 6-Sheet Posters

Boulevard 48-Sheet Poster	12
Boulevard Mini 48-Sheet Poster	12
6-Sheet Posters	12

Alcove Banners

Boulevard Alcove Banners	13
--------------------------	----

Boulevard Banner & In-Hall Banner

Boulevard Banner	14
In Hall Banner	14

DLR Walkway Sites

DLR Transverse Banner	15
DLR Mini Transverse Banner	15
DLR Triangle Banner	16
DLR Handrail Banner	16
DLR Facing Banner	17

Pennants, Flags & Taxi Banners

Podium Pennant Banner	18
Flags	18
Taxi Drop Off Banners	18

ICC Banners

ICC Staircase Banner	19
ICC Spiral Banner	19

Washroom Media Posters

Washroom Media Posters	20
------------------------	----

Bespoke Signage

Corporate Pedestals	21
Welcome Boards	21
Sentinels	21
Floor Graphics	21
Pop-ups	22
A Frames	22
External Carpark Signs	22

Bespoke Signage	
Pillar Wraps	22
Bannertite	23
Suspended Corridor Signage	23
Eatery Branding	
Table Tops	24
Eatery Surrounding Panels	24
Eatery Surrounding Roller Blinds	24
Branding Tower and Prince Regent Hanging Banners	
Branding Tower	25
Prince Regent Hanging Banners	25
Artwork, Templates & FTP's	26
Notes	27
Delivery & Storage	29
Collection	30
Terms & Conditions	31

How to use this document

Each of our sites has an artwork spec within this document, and will look like the example below:

The site reference refers to the site of that particular artwork. If the site is greyed out, the sizes do not apply to that particular artwork.

The artwork

The size will state the Overall size of the artwork, and the viewable area

What material the artwork should be supplied in

What fixings need to be applied to the artwork

Which FTP the artwork needs to be downloaded onto. All addresses for the FTP's can be found at the end of this booklet on page 26

The screenshot shows a document titled "DLR Walkway Sites" with the EXCEL LONDON INVISION logo. The main heading is "DLR Transverse Banner". Below this, there are four sections: "Size", "Material", "Fixings", and "Artwork Upload". To the right of these sections is a "Site Ref" table for a "Static Non-Lit Site". At the bottom of the document is a technical diagram of a banner with dimensions: 3584mm (top width), 3630mm (inner width), 1231mm (inner height), 1706mm (side height), and 5250mm (bottom width).

Site Ref					
Static Non-Lit Site					
A	B	C	D	E	F
G	H	I	J	K	

This is a diagram showing dimensions of the artwork

Hints & Tips

- ExCeL London is a beautifully sleek, modern venue and bright, bold advertising works really effectively.
- Try to avoid white backgrounds or expanses as they can lose impact and be lost against the setting (this is even more true for backlit sites).
- Keep messages simple. Too much text will make the viewer lose interest.
- Try something quirky, everybody remembers something that makes them smile.
- If advertising in more than one site, keep a theme or prominent logo. This will subliminally sink in with the viewer (whether they like it or not).
- If advertising at an event and using your stand number on the advertising be sure to check the number with the event organiser before submitting your final artwork (these can change while an event floorplan is still being finalised).
- Avoid anything offensive / illegal as this may result in your advertising not being displayed.
- Sites printed to mesh (i.e. DLR handrail banners , ICC Walkway Banners and Taxi drop off banners) will allow light through and therefore darker backgrounds and very bold, simple messages work better.
- If you would like to use specific colours but do not have Pantone references, send a sample of the ideal colour you would like with your artwork (for example an existing brochure or a carrier bag) and we will do our best to match it.
- Lastly, don't hesitate to contact a member of the Invision team for advice / assistance.

Hall Entrances

Hall Entrance Rear Panel

- **Size** Overall size = 12000 wide x 4000 high
Viewable area = 12000 wide x 4000 high
- **Material** Frontlit polyester reinforced PVC
- **Fixings** 9mm standard diameter Keder to top and sleeved bottom to take 20mm x 45mm timber batten
- **Artwork Upload** 1

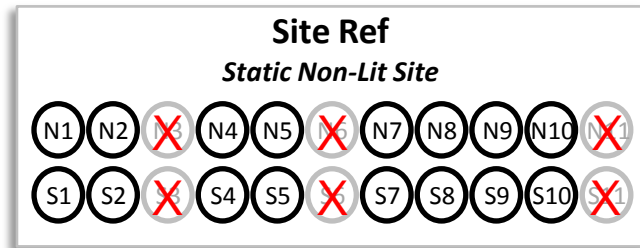

Hall Entrance Rear Vinyl

- **Size** Overall size = 6000 wide x 4000 high
Viewable area = 6000 wide x 4000 high
- **Material** *Not for production by client*
- **Fixings** *Not for production by client*
- **Artwork Upload** 4

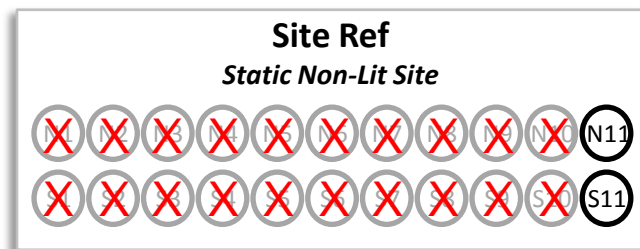

Hall Entrance Side Panel (Pair)

- **Size** Overall size = 3000 wide x 6500 high
Viewable area = 3000 wide x 6500 high
- **Material** Frontlit polyester reinforced PVC
- **Fixings** 9mm standard diameter Keder to top and sleeved bottom to take 20mm x 45mm timber batten
- **Artwork Upload** 1

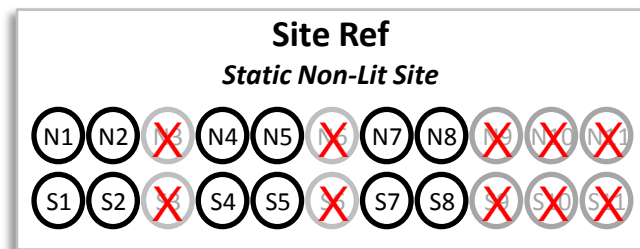

Lower Entrance Back Panels (Pair)

- **Size** Viewable area = 7220 wide x 995 high
- **Material** Backlit polyester reinforced PVC
- **Fixings** Produced to 3mm Foamex panels
- **Artwork Upload** 1

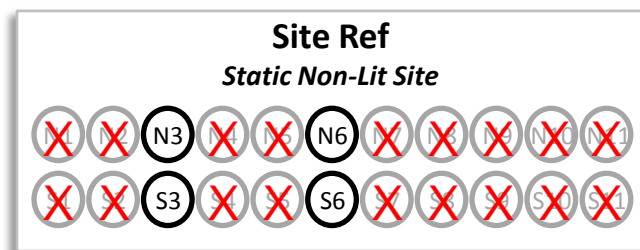

Hall Entrances

Lower Entrance Front Panels (Pair)

- **Size**
 - N3 Left Viewable area = 7380 wide x 990 high
 - N3 Right Viewable area = 7410 wide x 990 high
 - S3 Left Viewable area = 7390 wide x 990 high
 - S3 Right Viewable area = 7385 wide x 990 high
 - N6 Left Viewable area = 7390 wide x 990 high
 - N6 Right Viewable area = 7405 wide x 990 high
 - S6 Left Viewable area = 7405 wide x 990 high
 - S6 Right Viewable area = 7385 wide x 990 high

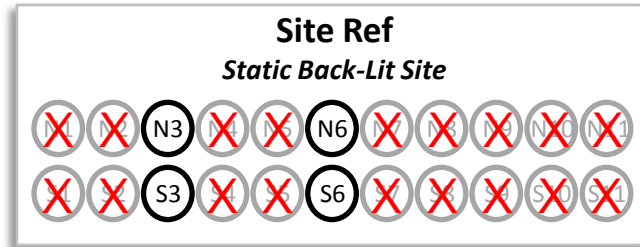

Please allow a 35mm bleed to each side

- **Material** Backlit polyester reinforced PVC
- **Fixings** All have spring fixings
- **Artwork Upload** 1

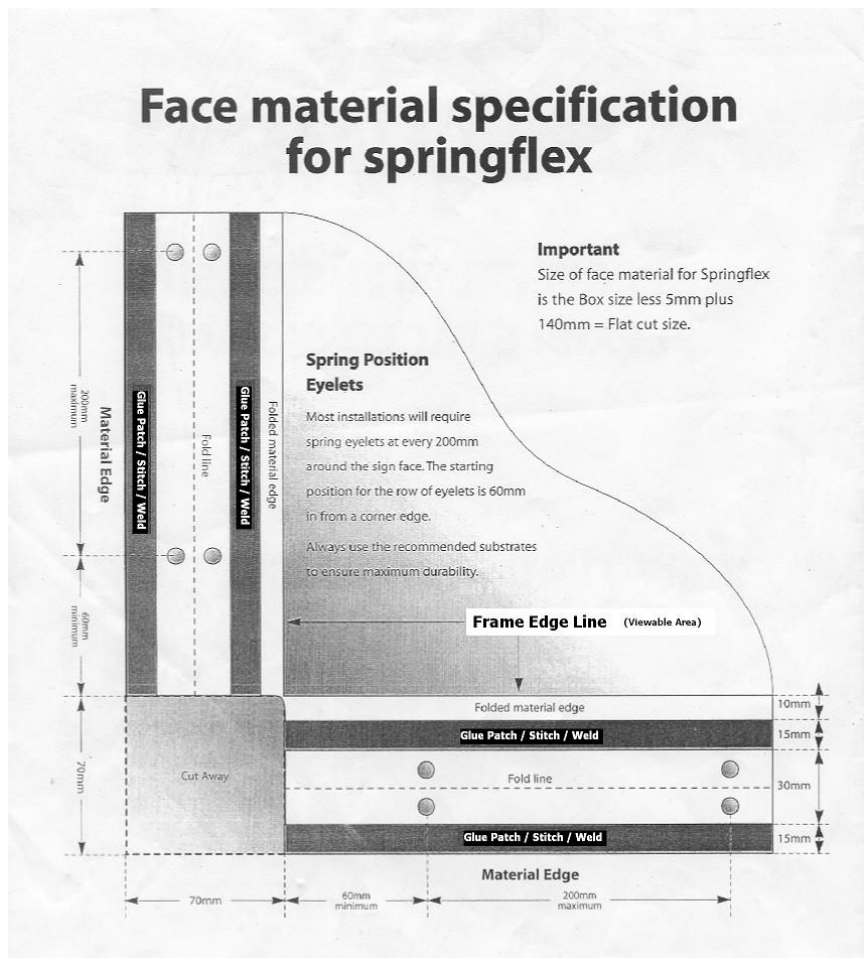

Hall Entrances

Hall Entrance Totems

- **Size** Overall size = 841 wide x 2704 high
Viewable area = 811 wide x 2674 high
- **Material** All posters to be trimmed and printed to Polyester Backprint film
- **Fixings** Clip Frame
- **Artwork Upload** 2

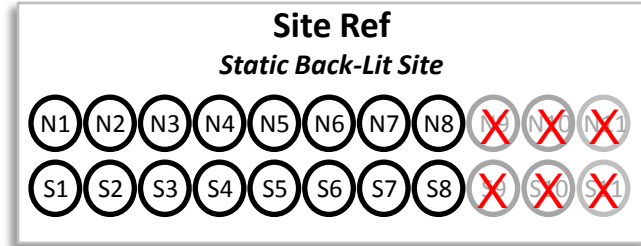

- **Size** Overall size = 930 wide x 2820 high
Viewable area = 880 wide x 2780 high
- **Material** All posters to be trimmed and printed to Polyester Backprint film
- **Fixings** Clip Frame
- **Artwork Upload** 2

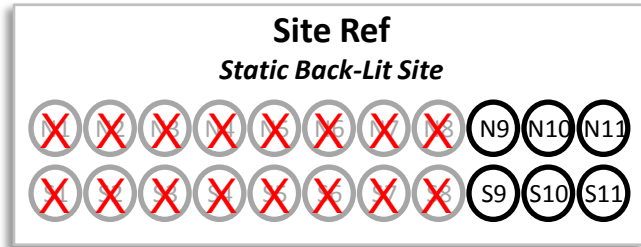

- **Size** Overall size = 1420 wide x 2820 high
Viewable area = 1380 wide x 2780 high
- **Material** All posters to be trimmed and printed to Polyester Backprint film
- **Fixings** Clip Frame
- **Artwork Upload** 2

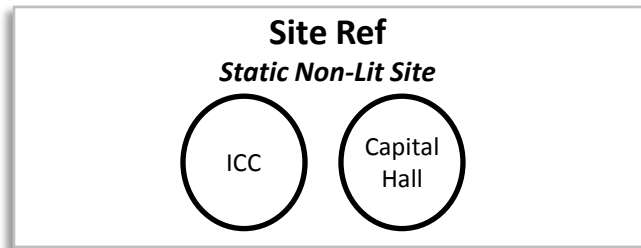

Hall Entrance Totem Banners

- **Size** Overall size = 1000 wide x 5000 high
Viewable area = 1000 wide x 5000 high
- **Material** Double-sided Opaque P.V.C
- **Fixings** All edges to be double stitched and welded
- **Artwork Upload** 1

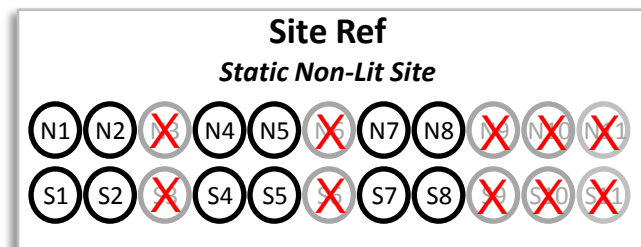
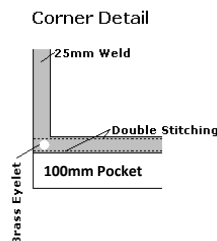
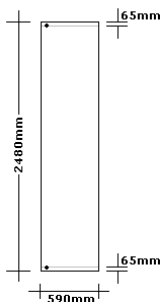

Pyramid

Pyramid Welcome Banner

- **Size** Overall size = 12000 wide x 2500 high
Viewable area = 12000 wide x 2500 high
- **Material** Polyester Reinforced P.V.C.
- **Fixings** To be finished with specialist stitching on all edges and reinforced corners. Stainless steel, 5mm width, 1 inch, D-rings to be fitted to each corner (to take a weight loading of 500kg).
- **Artwork Upload** 1

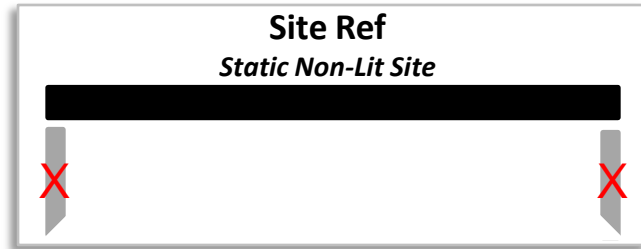

Pyramid Shaped Banner

- **Size** See below - Diagram shown is for the South Side, reverse image for North.

The artwork should bleed to the outer edges of the poster.
- **Material** Polyester Reinforced P.V.C.
- **Fixings** To be finished with specialist stitching on all edges and reinforced corners. Stainless steel, 5mm width, 1 inch, D-rings to be fitted to each corner (to take a weight loading of 500kg).
- **Artwork Upload** 1

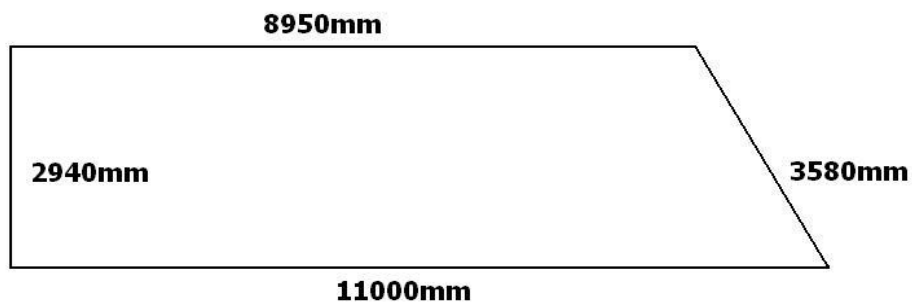
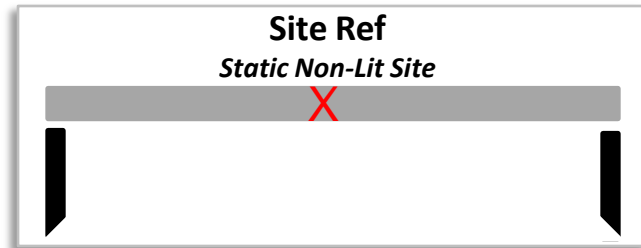

96-Sheet Posters

Boulevard 96-Sheet Poster

- **Size** Overall size (inc Keder) = 12230 wide x 3175 high
Viewable area = 12153 wide x 3084 high
- **Material** Backlit Polyester Reinforced P.V.C.
- **Fixings** 9mm standard diameter Keder to all 4 sides
- **Artwork Upload** 1

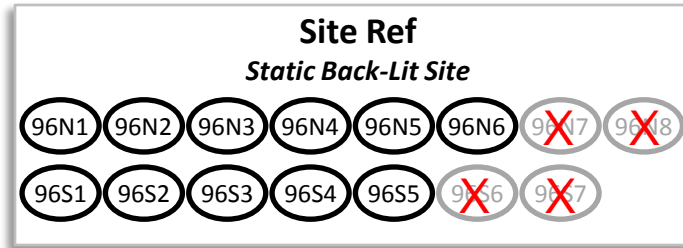

- **Size** Overall size (inc Keder) = 12260 wide x 3125 high
Viewable area = 12178 wide x 3044 high
- **Material** Backlit Polyester Reinforced P.V.C.
- **Fixings** 9mm standard diameter Keder to all 4 sides
- **Artwork Upload** 1

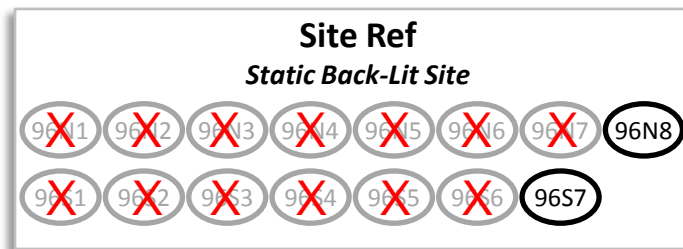

Boulevard Crop 96-Sheet Poster

- **Size** Overall size (inc Keder) = 9984 wide x 3125 high
Viewable area = 9902 wide x 3044 high
- **Material** Backlit Polyester Reinforced P.V.C.
- **Fixings** 9mm standard diameter Keder to all 4 sides
- **Artwork Upload** 1

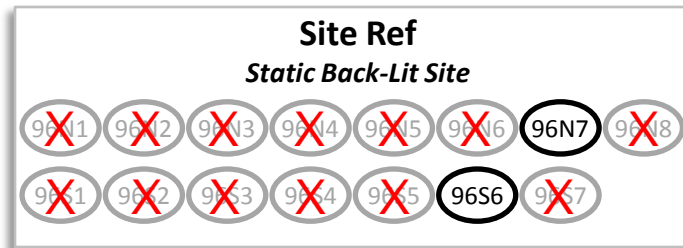

External 96-Sheet Poster

- **Size** Overall size (inc Keder) = 12242 wide x 3185 high
Viewable area = 12153 wide x 3084 high
- **Material** Backlit Polyester Reinforced P.V.C.
- **Fixings** 9mm standard diameter Keder to all 4 sides
- **Artwork Upload** 1

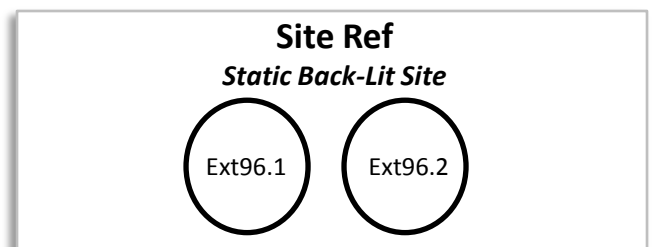

48-Sheet Posters & 6-Sheet Posters

Boulevard 48-Sheet Poster

- **Size** Overall size (inc Keder) = 6180 wide x 3125 high
Viewable area = 6096 wide x 3044 high
- **Material** Backlit Polyester Reinforced P.V.C.
- **Fixings** 9mm standard diameter Keder to all 4 sides
- **Artwork Upload** 1

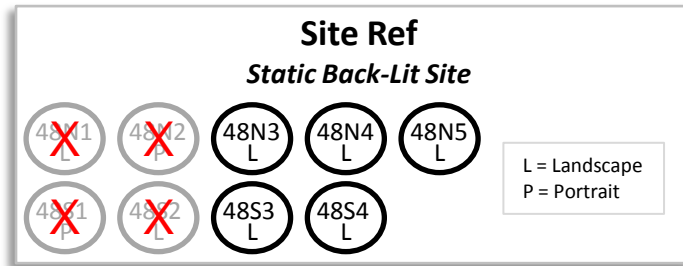

Boulevard Mini 48-Sheet Poster - Landscape

- **Size** Overall size (inc Keder) = 3920 wide x 1860 high
Viewable area = 3832 wide x 1772 high
- **Material** Backlit Polyester Reinforced P.V.C.
- **Fixings** 9mm standard diameter Keder to all 4 sides
- **Artwork Upload** 1

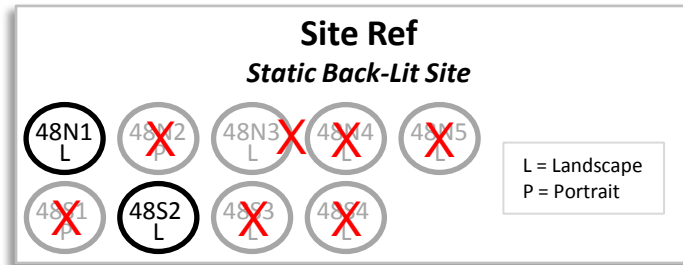

Boulevard Mini 48-Sheet Poster - Portrait

- **Size** Overall size (inc Keder) = 1860 wide x 3920 high
Viewable area = 1772 wide x 3832 high
- **Material** Backlit Polyester Reinforced P.V.C.
- **Fixings** 9mm standard diameter Keder to all 4 sides
- **Artwork Upload** 1

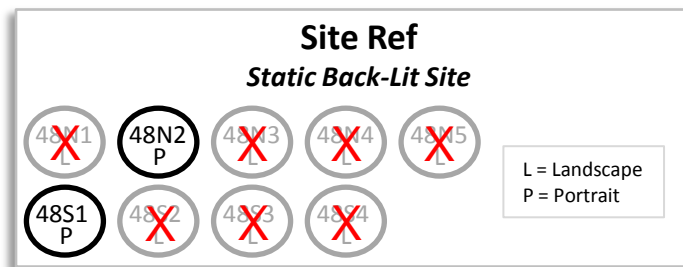

6-Sheet Posters

- **Size** Overall size = 1200 wide x 1810 high
Viewable area = 1160 wide x 1760 high
- **Material** Backlit Paper
- **Fixings** All posters to be trimmed. External posters will need to be encapsulated
- **Artwork Upload** 1

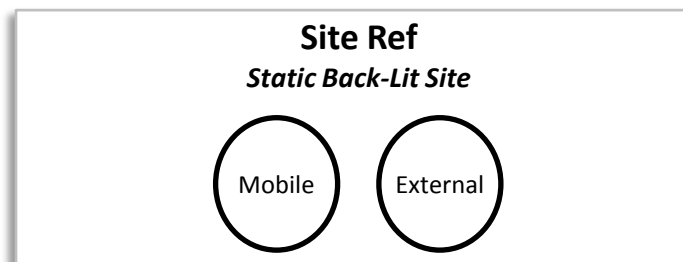

Alcove Banners

Boulevard Alcove Banners

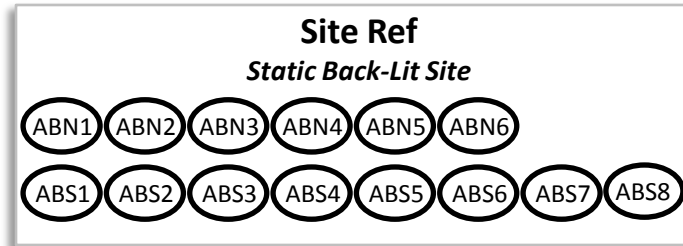

- **Size**
- | | |
|------|---------------------------------------------------------|
| ABN1 | Overall & viewable size = 5550 wide (A) x 5360 high (B) |
| ABN2 | Overall & viewable size = 5600 wide (A) x 5370 high (B) |
| ABN3 | Overall & viewable size = 6450 wide (A) x 5400 high (B) |
| ABN4 | Overall & viewable size = 5600 wide (A) x 5340 high (B) |
| ABN5 | Overall & viewable size = 5600 wide (A) x 5410 high (B) |
| ABN6 | Overall & viewable size = 6550 wide (A) x 5460 high (B) |
| ABS1 | Overall & viewable size = 5590 wide (A) x 5360 high (B) |
| ABS2 | Overall & viewable size = 6500 wide (A) x 5360 high (B) |
| ABS3 | Overall & viewable size = 5600 wide (A) x 5360 high (B) |
| ABS4 | Overall & viewable size = 5600 wide (A) x 5360 high (B) |
| ABS5 | Overall & viewable size = 6460 wide (A) x 5360 high (B) |
| ABS6 | Overall & viewable size = 5840 wide (A) x 5430 high (B) |
| ABS7 | Overall & viewable size = 5750 wide (A) x 5480 high (B) |
| ABS8 | Overall & viewable size = 6500 wide (A) x 5490 high (B) |

The artwork should include a 10mm bleed to the outer edges of the poster.

- **Material** Polyester Reinforced P.V.C.
- **Fixings** Boulevard alcove banners to be finished with specialist stitching on all edges and reinforced corners. Stainless steel, 5mm width, 1 inch, D-rings to be fitted to each corner (to take a weight loading of 500kg).
- **Artwork Upload** 1 - EPS artwork template available on FTP

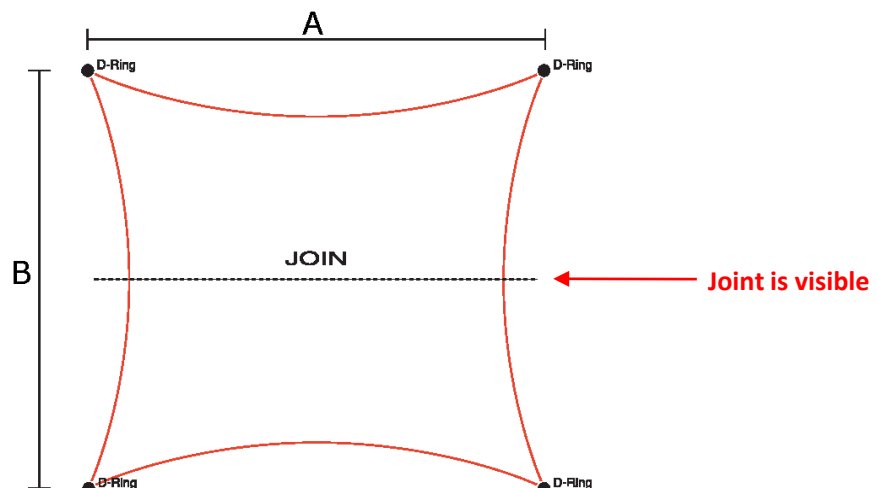

Boulevard Banner & In-Hall Banner

Boulevard Banner

- **Size** Overall size = 12000 wide x 3150 high
Artwork should bleed to the outer edges of the poster.
- **Material** Polyester Reinforced P.V.C.
- **Fixings** The artwork should bleed to the outer edges of the poster. Boulevard banners to be finished with specialist stitching on all edges and reinforced corners. Stainless steel, 5mm width, 1 inch, D-rings to be fitted to each corner (to take a weight loading of 500kg).
- **Artwork Upload** 1 - EPS artwork template available on FTP

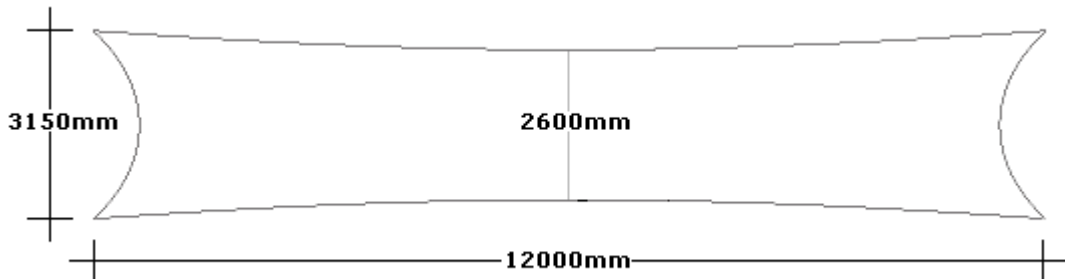
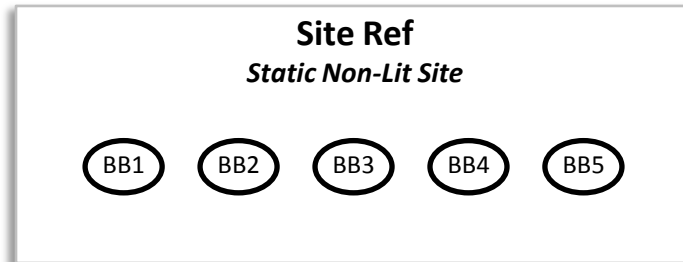

In-Hall Perimeter Banner

- **Size** Overall size = 6100 wide x 2950 high
Viewable area = 6100 wide x 2950 high
- **Material** Polyester Reinforced P.V.C.
- **Fixings** These banners will be rigged at a height of 7m from ground to bottom of banner. Sleeved top and bottom to take 50mm diameter pole
- **Artwork Upload** 1 - EPS artwork template available on FTP

DLR Walkway Sites

DLR Transverse Banner

- **Size** See Diagram Below
Artwork should bleed to the outer edges of the poster.
- **Material** Polyester Reinforced P.V.C.
- **Fixings** Banners to be finished with specialist stitching on all edges and reinforced corners. Stainless steel, 5mm width, 1 inch, D-rings to be fitted to each corner (to take a weight loading of 500kg).
- **Artwork Upload** 1 - EPS artwork template available on FTP

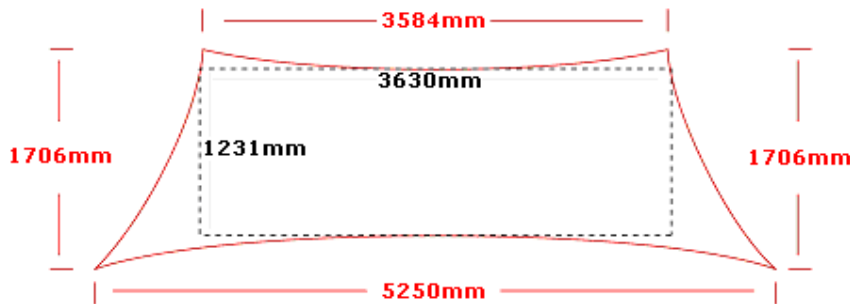
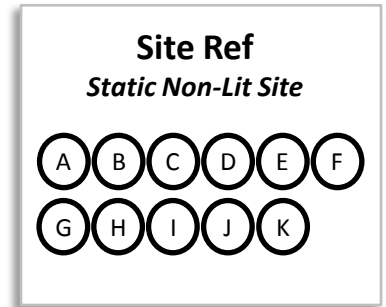

DLR Mini Transverse Banner

- **Size** See Diagram Below
Artwork should bleed to the outer edges of the poster.
- **Material** Polyester Reinforced P.V.C.
- **Fixings** Banners to be finished with specialist stitching on all edges and reinforced corners. Stainless steel, 5mm width, 1 inch, D-rings to be fitted to each corner (to take a weight loading of 500kg).
- **Artwork Upload** 1 - EPS artwork template available on FTP

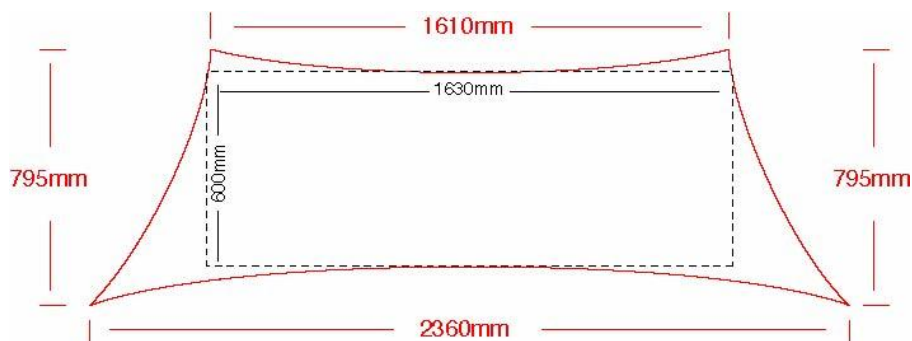
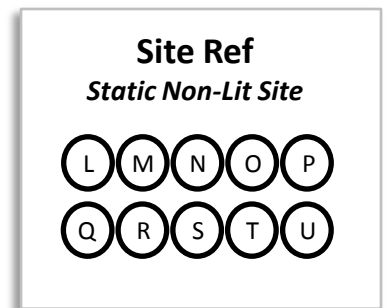

DLR Walkway Sites

DLR Triangle Banner

- **Size** See Diagram Below
Artwork should bleed to the outer edges of the poster.
- **Material** Polyester Reinforced P.V.C.
- **Fixings** Banners to be finished with specialist stitching on all edges and reinforced corners. Stainless steel, 5mm width, 1 inch, D-rings to be fitted to each corner (to take a weight loading of 500kg).
- **Artwork Upload** 1 - EPS artwork template available on FTP

Site Ref
Static Non-Lit Site

1 - 30

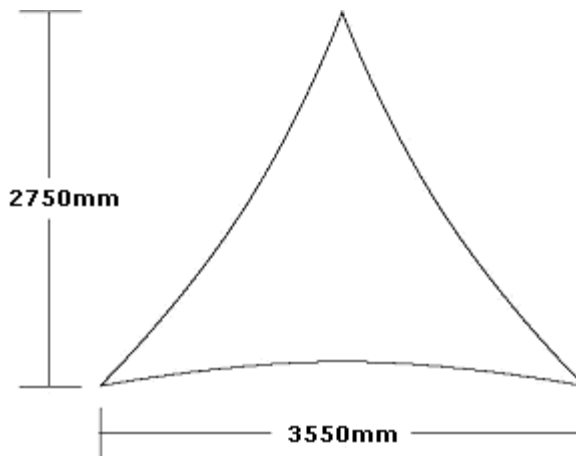

DLR Handrail Banners

- **Size** Overall size = 3870 wide x 2120 high
Viewable size = 3870 wide x 2120 high
- **Material** These banners are produced to a mesh material and will allow some light through. Both sides acrylic lacquered
- **Fixings** Eyelets top and bottom
- **Artwork Upload** 1 - EPS artwork template available on FTP

Site Ref
Static Non-Lit Site

1 - 44

DLR Walkway Sites

DLR Facing Banner

- **Size** Overall size = 2775 wide x 1800 high
Viewable area = 2775 wide x 1800 high
- **Material** These banners are produced to a mesh material and will allow some light through.
- **Fixings** Banners to be finished with specialist stitching on all edges and reinforced corners. Stainless steel, 5mm width, 1 inch, D-rings to be fitted to each corner (to take a weight loading of 500kg).
- **Artwork Upload** 1 - EPS artwork template available on FTP

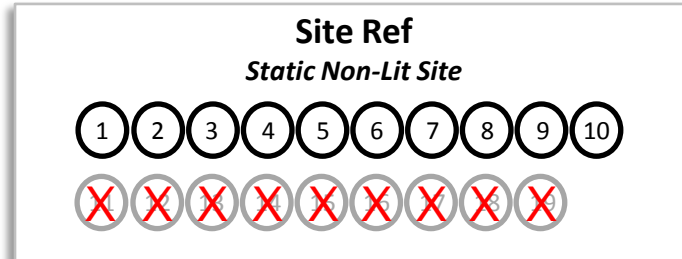

- **Size** Overall size = 2250 wide x 1800 high
Viewable area = 2250 wide x 1800 high
- **Material** These banners are produced to a mesh material and will allow some light through.
- **Fixings** Banners to be finished with specialist stitching on all edges and reinforced corners. Stainless steel, 5mm width, 1 inch, D-rings to be fitted to each corner (to take a weight loading of 500kg).
- **Artwork Upload** 1 - EPS artwork template available on FTP

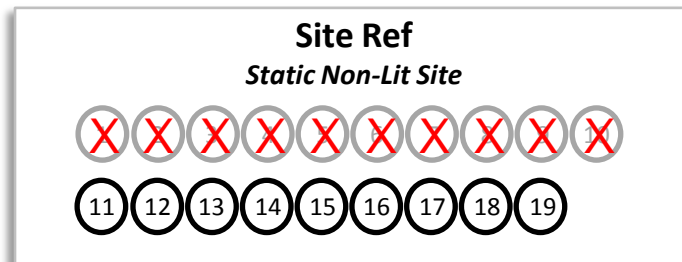

Pennants, Flags & Taxi Banners

Podium Pennant Banner (Double Sided)

- **Size** Overall size = 590 wide x 1200 high
Viewable area = 590 wide x 1200 high
The artwork should bleed to the outer edges of the poster
- **Material** Opaque Polyester Reinforced P.V.C.
- **Fixings** All edges to be double stitched and welded (see Totem Banners)
- **Artwork Upload** 1 - EPS artwork template available on FTP

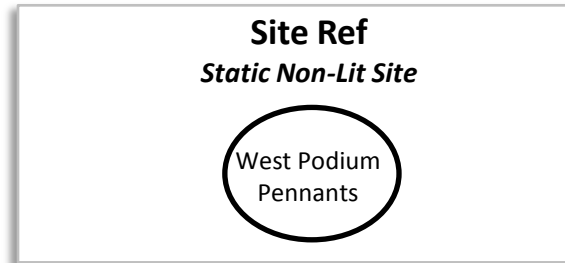

Flags

- **Size** Overall size = 1000 wide x 2450 high
Viewable area = 1000 wide x 2450 high
Other sizes available on request
- **Material** Various
- **Fixings** To be supplied fully roped and toggled. Standard toggle to top and nylon loop to the bottom.
- **Artwork Upload** 6

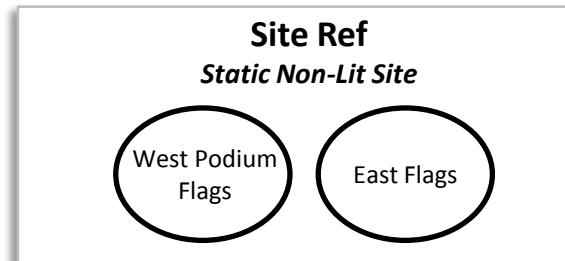

Taxi Drop Off Banners

- **Size** Overall size = 2700 wide x 2500 high
Viewable area = 2700 wide x 2500 high
- **Material** *Not for production by client*
- **Fixings** *Not for production by client*
- **Artwork Upload** 1

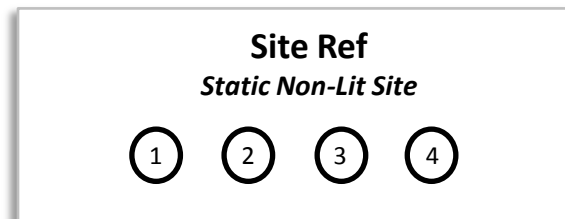

ICC Banners

ICC Staircase Banner

- **Size** **This is a double-sided banner. However the viewable sizes are different on each side due to the position of the banner.**

Overall size = 4000 wide x 6000 high
Viewable area = East Facing - 4000 wide x 4100 high
West Facing - 4000 wide x 6000 high

- **Material** **Not for production by client**
- **Fixings** **Not for production by client**
- **Artwork Upload** **1**

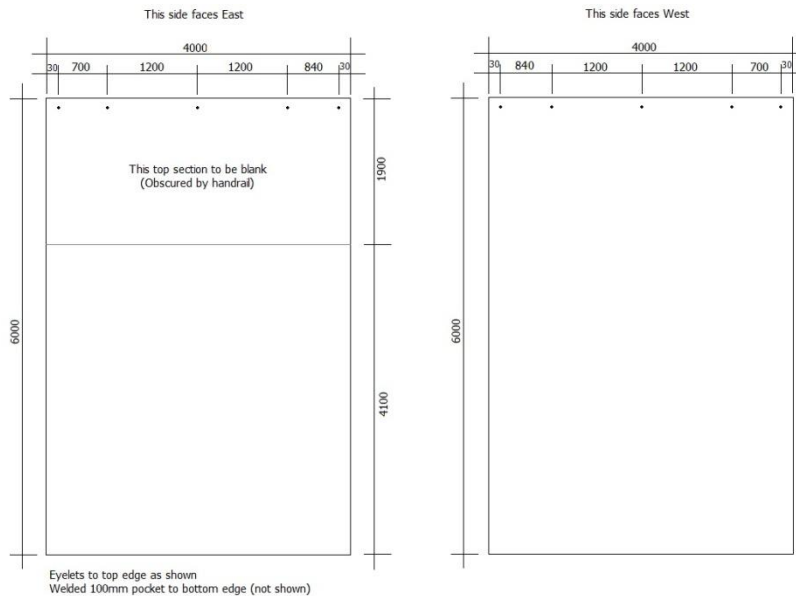
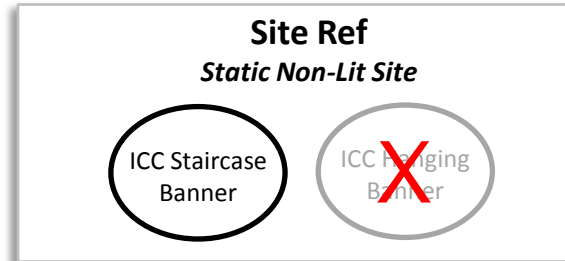

ICC Spiral Banner

- **Size** Overall size = 7260 wide x 6500 high
Viewable area = 7260 wide x 6500 high

- **Material** **Not for production by client**
- **Fixings** **Not for production by client**
- **Artwork Upload** **1**

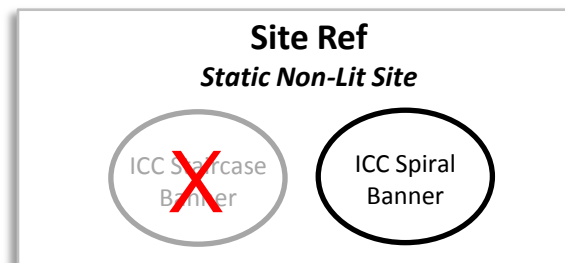

Washroom Media Posters

Washroom Media Posters

- **Size**

A4 Poster
Overall size = A4 Portrait
Bleed of 15mm all round

A3 Poster
Overall size = A3 Portrait
Bleed of 10mm all round
- **Material**

Produce to high quality paper and trimmed. Some additional prints are produced and delivered to allow for damage etc.
- **Fixings**

Clip frame
- **Artwork Upload**

5

LOCATION	SIZE	TOTAL NUMBER
N2 WC	A3	32 (7)
N5 WC	A4	26 (2)
N7 WC	A4	25 (2)
N9 WC	A4	25 (2)
N11 WC	A4	26 (3)
N13 WC	A4	25 (2)
N15 WC	A4	31 (3)
N21 WC	A3	30 (3)
Boulevard B-WC	A3	51 (7)
Platinum Suite Level 3	A4	41 (10)
PR WC	A3	24 (2)
ICC WC2	A3	58 (4)

LOCATION	SIZE	TOTAL NUMBER
S3 WC	A4	24 (2)
S5 WC	A4	24 (2)
S7 WC	A4	25 (2)
S9 WC	A4	25 (2)
S11 WC	A4	24 (2)
S13 WC	A4	25 (2)
S15 WC	A4	24 (2)
S19 WC	A3	30 (3)
Phase 2 Level 2	A3	7 (1)
Phase 2 Level 3	A3	40 (5)
Level 0 Below Ent S9	A3	40 (5)

Numbers in brackets are posters over urinals. These are included in the total displayed rather than additional. The washroom walls are moveable and the ratio of male/female toilets is based on the expected visitor attendance.

Bespoke Signage

Corporate Pedestals

- **Size** Overall size = 594 wide x 841 high
Viewable area = 579 wide x 826 high
- **Material** 250 gsm Paper
- **Fixings** Clip frame
- **Artwork** 1
Upload

Welcome Boards

- **Size** Overall size = 1000 wide x 1500 high
Viewable area = 1000 wide x 1425 high (from the top of the stand)
- **Material** 10mm Foam core
- **Fixings** Slides into base frame
- **Artwork** 1
Upload

Sentinels

- **Size** Overall size = 1023 wide x 1528 high
Viewable area = 975 wide x 1480 high
- **Material** 250g Paper
- **Fixings** Set behind Perspex panel
- **Artwork** 1
Upload

Floor Graphics

- **Size** Various sizes available, please refer to your contract for details
- **Material** *Not for production by client*
- **Fixings** *Not for production by client*
- **Artwork** 2
Upload

Bespoke Signage

Pop-ups

- **Size** Overall size = 850 wide x 2400 high
Viewable area = 850 wide x 2150 high
- **Material** *Not for production by client*
- **Fixings** *Not for production by client*
- **Artwork** 8
Upload

A Frames

- **Size** Overall size = 594 wide x 841 high
Viewable area = 579 wide x 826 high
- **Material** 250 gsm Paper
- **Fixings** Clip frame
- **Artwork** 1
Upload

External Carpark Signs

- **Size** Overall size = 594 wide x 841 high
Viewable area = 579 wide x 826 high
- **Material** 250 gsm Encapsulated Paper.
- **Fixings** Set behind Perspex panel
- **Artwork** 1
Upload

Pillar Wraps

- **Size** Overall size = 750 wide x 2000 high each of 4 sides
Viewable area = 740 wide x 1990 high each of 4 sides
Available on perpendicular Pillars only. Please supply each side of the pillar wrap as a separate piece of artwork.
- **Material** *Not for production by client*
- **Fixings** *Not for production by client*
- **Artwork** 2
Upload

Bespoke Signage

Bannertite

- **Size** The bannertite comes in a variety of sizes:
 1 - Overall & Viewable size = 2000 wide x 2000 high
 2 - Overall & Viewable size = 4000 wide x 2000 high
 3 - Overall & Viewable size = 6000 wide x 2000 high
- **Material** *Not for production by client*
- **Fixings** *Not for production by client*
- **Artwork** 4
 Upload

Suspended Corridor Signage

Not available for Capital Suite

- | | |
|-----------------------------------------------------------------------------------------------------------------------------------------------------------------------------------------------------------------------------------------------------------------------------------------------------------------------------------------------------------------------------------------------------|---------------------------------------------------------------------------------------------------------------------------------------------------------------------|
| <ul style="list-style-type: none"> • Size East/West Facing
 Overall & Viewable size = 500 wide x 250 high • Material <i>Not for production by client</i> • Fixings <i>Not for production by client</i> • Artwork 2
 Upload | <ul style="list-style-type: none"> • SS Lift Facing
 Overall & Viewable size = 500 wide x 250 high |
|-----------------------------------------------------------------------------------------------------------------------------------------------------------------------------------------------------------------------------------------------------------------------------------------------------------------------------------------------------------------------------------------------------|---------------------------------------------------------------------------------------------------------------------------------------------------------------------|

Eatery Branding

Table Tops

- **Size** Eateries have both types of table and therefore artworks for both the square and circular tables should be supplied.

Circular tables

Overall & Viewable size = 580mm

Square tables

Overall & Viewable size = 580mm wide x 580mm high

- **Material** *Not for production by client*
- **Fixings** *Not for production by client*
- **Artwork Upload** 2

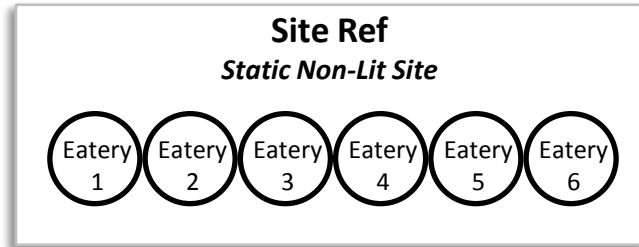

Eatery Surrounding Panels

- **Size** Overall size = 1865mm wide x 1000mm high
Viewable size = 1865mm wide x 1000mm high

- **Material** *Not for production by client*
- **Fixings** *Not for production by client*
- **Artwork Upload** 2

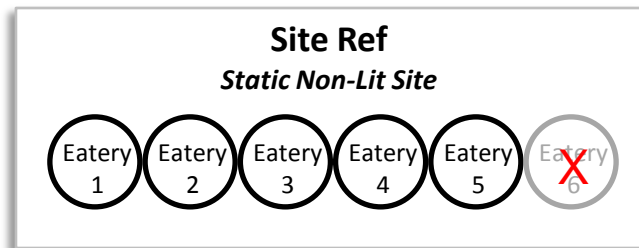

Eatery Surrounding Roller Blinds

- **Size** Overall size = 1495mm wide x 780mm high

- **Material** *Not for production by client*
- **Fixings** *Not for production by client*
- **Artwork Upload** 3

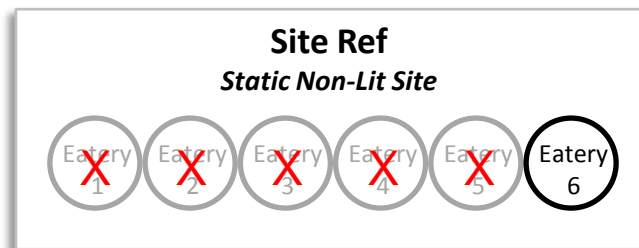

Branding Tower and Prince Regent Hanging Banners

Branding Tower

- **Size** Each Panel is:
Overall size = 1500mm wide x 3800mm high
- **Material** *Not for production by client*
- **Fixings** Freestanding unit
- **Artwork Upload** 7

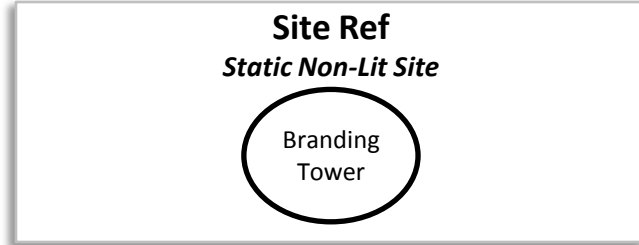

Prince Regent Hanging Banners

- **Size** Overall size = 6000mm wide x 1000mm high
- **Material** Polyester Reinforced P.V.C.
- **Fixings** Pocket top and bottom
- **Artwork Upload** 1

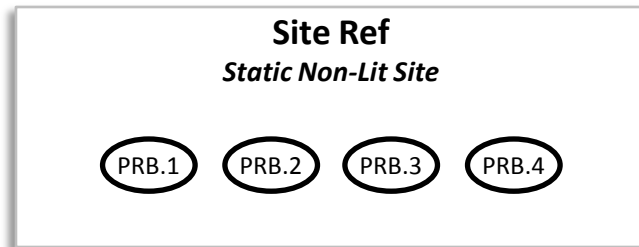

Prince Regent Hanging Banners

- **Size** Overall size = 2500mm wide x 1000mm high
- **Material** Polyester Reinforced P.V.C.
- **Fixings** Pocket top and bottom
- **Artwork Upload** 1

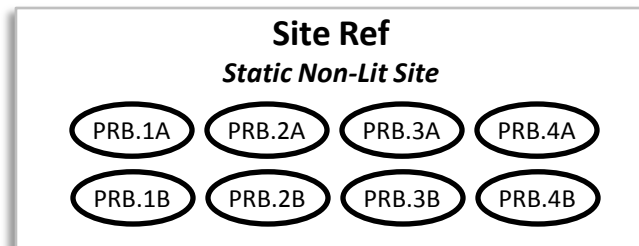

Artwork, Templates & FTP's

Artwork Supply

Please supply on CD / DVD or upload to FTP.

Artwork Upload:

Artwork Upload 1:

FTP Address: <ftp://217.35.77.128>

FTP Username: excel2

FTP Password: excelftp

Artwork Upload 2:

Email: Sales@Completestudiographics.co.uk

FTP Address:

<ftp2.completestudiographics.co.uk>

FTP Username: CUser12

FTP Password: reminder

Artwork Upload 3:

Email: invision@excel-london.co.uk

Address: <ftp://87.127.29.69>

Username: excel2

Password: excelftp

Artwork Upload 4:

FTP Address: <ftp://ftp.insite-ms.com>

FTP Username: insite-ms.com

FTP Password: insite2008

Artwork Upload 5:

Email: shop@abbotprint.co.uk

Artwork Upload 6:

Email: Lee.Johnston@harrisoneds.com

Artwork Upload 7:

<http://dropbox.yousendit.com/PaulGraves11670106>

Artwork Upload 8:

Address: <ftp://pertonsigns.ftpstream.com>

If uploading to the FTP please create a folder in the name of the exhibitor and e-mail confirmation to lynnfelton@excel-london.co.uk, katieleebarker@excel-london.co.uk or rebeccaHarlow@excel-london.co.uk once the artwork is fully uploaded.

Templates

Artwork & Outline templates for all shaped banners are available for download on our FTP site at:

Address: <ftp://87.127.29.69>

Username: exceltemplates

Password: excel

Any file manipulation or high resolution scanning required will incur an additional charge.

NB. It is the client's responsibility to view the artwork at full size prior to submitting to make sure it is of good enough quality. It is not Invisions responsibility to check the files for quality or errors once submitted for printing. If the artwork is printed and is to poor quality or has errors the client is liable for the re-print costs.

Notes

Acceptable Programmes

We require final approved artwork in:-

- Adobe Indesign CS5
- Adobe Illustrator CS5
- Adobe Photoshop CS5
- Quark Xpress 7
- Freehand MX (plus all earlier versions of these programs).

Artwork created in signwriting programs can usually be accepted when exported as .ai or .eps files.

If .pdf documents are being used they must be formatted correctly with NO trim marks or registration marks inside the 'bleed' area.

Fonts

Please ensure all fonts used (both screen and printer fonts) are included. Where possible convert fonts to paths / outlines, particularly for PC generated files. Fonts must be compressed ('stuffed' or 'zipped') prior to dispatch or corruption can occur.

Logos: Any logos should be created in Illustrator or Freehand for best quality.

Photographic Images

For images to be reproduced, without pixilation, a minimum resolution of 45 pixels per inch at full size is required. 100ppi at full size produces a very good quality print (but a very large file). Copyright is the responsibility of the client and ExCeL London Invision cannot take any responsibility for this.

Colours

Our printing system uses a variation of the four colour process system and cannot always match Pantone colours exactly. We will gladly run small colour tests, if required, prior to production (deadlines permitting).

All blacks to be C=40%, M=40%, Y=40% & B=100% (i.e. made up of 4 colours). Please note that failure to comply may result in substandard production, particularly where sites are backlit.

Artwork size

Please ensure that the artwork is sized to the viewable area with any necessary bleed extending out to the overall size.

File size

If possible keep the file size below 500MB uncompressed (particularly if uploading to the FTP site) and keep any file compression to a minimum to preserve final image quality.

Document layout

Artwork should be created in the correct proportion to the final image size, not forgetting any image bleed required. Any placed images and logos must also be included with the artwork.

Shaped banners should have the outline template included in the layout to ensure no elements are lost when the banner is cut to shape.

Proofs

2 A4 or A3 colour Chromalin laser proofs and any Pantone reference must be supplied with all artwork (if uploading to the FTP please send these via 1st class post).

Where more than one artwork design is to be used this must be clearly stated, in writing, with the first piece of artwork at time of receipt. Failure to do so may result in a reprint cost for new additional artwork.

Where artworks are to be placed in a specific order, i.e. where more than one of the same site has been purchased, the plan must be submitted with the artwork. Failure to do so may result in a labour cost for repositioning the posters.

Lead times

Artwork and proofs should be received, by ExCeL London Invision, by the date stated on the signed order confirmation or the date agreed, in writing, between the client and the Account Manager. Any artwork received after this time will be subject to a 30% surcharge.

Liability

Where ExCeL London Invision are responsible for the production of graphics, full responsibility will rest with ExCeL London Invision only once complete approved artwork and a full colour proof have been received from the client within the agreed timeframe.

Production

Keder spec

9mm standard diameter.

Keder of a larger or smaller diameter is not acceptable.

Stretched vinyls

For all vinyl sites where the graphic will be stretched during installation, soft flexible banner vinyl should be used.

Delivery & Storage

Packaging for delivery

All PVC banners and signage to be rolled onto a huge core tube and bubble wrapped, clearly labelled with client, poster reference, event name, specific installation instructions, where necessary, and installation date information.

Please roll the posters so that the top left edge is on the outside. Please indicate the top left edge by marking the rear of the Keder (not on the graphic itself).

6-sheet and totem graphics are to be rolled into a cardboard tube of sufficient diameter

All Washroom Media A4/A3 posters are to be supplied boxed.

Delivery

All posters / banners etc should be delivered, between 09.00hrs & 16.00hrs Monday to Friday, to:

ExCeL London Invision
Traffic Office
K Warehouse
One Western Gateway
Royal Victoria Dock
London
E16 1XL

Where possible deliveries should be made by courier or recorded delivery and signed for by a member of the ExCeL London Invision team to ensure their safe receipt.

Storage of all posters and artwork

All posters, artwork and artwork discs will be disposed of immediately after the last day of tenancy unless prior arrangement for collection has been made and agreed.

Any posters that are stored for collection, by request, but not collected on the appointed collection date will be immediately disposed of and a disposal fee will be payable by the client (as per the signed order confirmation).

Collection of artwork

Your signage can be collected on the specified and pre-arranged date between the hours of 9.00am and 3.00pm from the address below.

A collection note will be emailed to you for completion shortly after your event and this must be emailed to ExCel London InVision in advance of collection. The person collecting / courier must also have a copy with them when they arrive to identify the correct signage.

Any signage not collected by the specified dates will be disposed of and recycled where possible. Please note that some signage cannot be retained due to the nature of its removal such as washroom posters, table-top branding and vinyl graphics.

When you arrive at the Traffic office, please contact Alasdair MacDonald on 07904638940

Traffic Office
Sandstone Lane
Royal Victoria Dock
London
E16 1XL

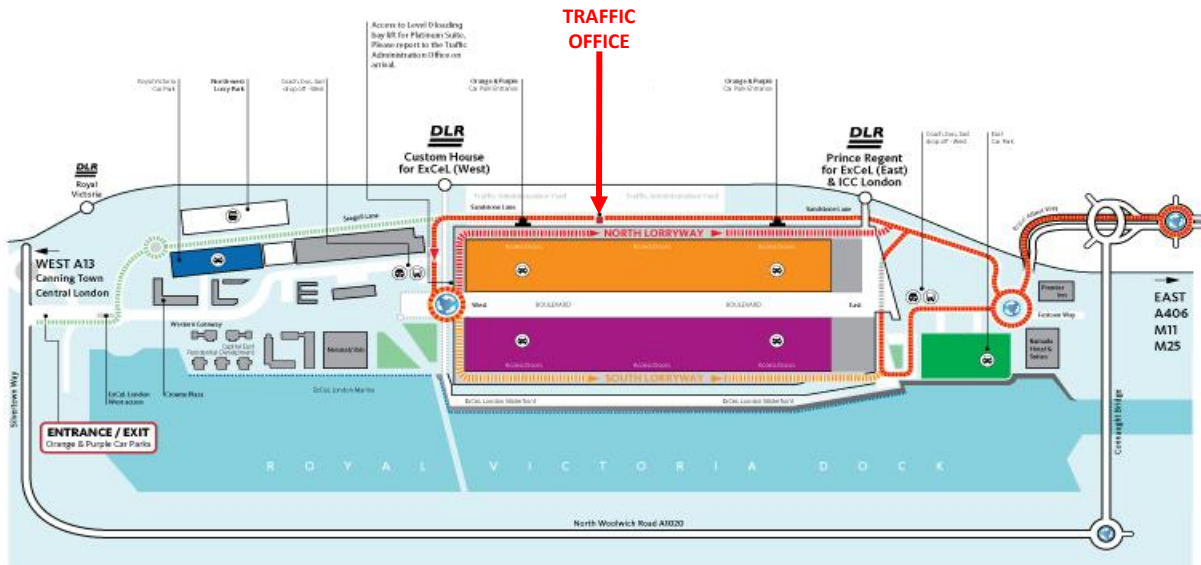

Key

	Royal Victoria Car Park		Docklands Light Rail
	Orange Car Park		Berthing points
	Purple Car Park		Primary access for vehicles during build-up and break-down from Peruvian Wharf
	East Car Park		Secondary access to staff administration - not advisable for large vehicles