

**EXCEL**

**LONDON**

**INVISION**

---

**ARTWORK  
SPECIFICATION SHEET  
&  
TERMS & CONDITIONS**

---

# CONTENTS

## ARTWORK SPECIFICATIONS

PAGES 3 – 12

## HINTS AND TIPS

PAGES 13

## TERMS AND CONDITIONS

PAGES 14 - 16

## **SPECIFICATIONS.**

### **STATIC, BACKLIT SITES**

**ALL MEASUREMENTS ARE IN MILLIMETRES**

#### **Boulevard 96-sheet poster**

Size: Overall size = 12,242 wide x 3,185 high  
Viewable area = 12,153 wide x 3,084 high

#### **External 96-sheet poster**

Size: Overall size = 12,242 wide x 3,185 high  
Viewable area = 12,153 wide x 3,084 high

#### **Mini-96-sheet poster**

Size: Overall size = 8,040 wide x 1,860 high  
Viewable area = 7,952 wide x 1,772 high

#### **Boulevard mini-48-sheet poster**

Size: Overall size = 3,920 wide x 1,860 high  
Viewable area = 3,832 wide x 1,772 high

#### **6-sheet poster sites - mobile and external**

Size: Overall size = 1,200 wide x 1,810 high  
Viewable area = 1,160 wide x 1,760 high

#### **Hall entrance - lower lightbox entrance (front only)**

Site: S3 Left Viewable area = 7,400 wide x 1,000 high. Allow 35mm bleed to each side  
S3 Right Viewable area = 7,395 wide x 1,000 high. Allow 35mm bleed to each side

Site: S6 Left Viewable area = 7,415 wide x 1,000 high. Allow 35mm bleed to each side  
S6 Right Viewable area = 7,395 wide x 1,000 high. Allow 35mm bleed to each side

Site: N3 Left Viewable area = 7,390 wide x 1,000 high. Allow 35mm bleed to each side  
N3 Right Viewable area = 7,420 wide x 1,000 high. Allow 35mm bleed to each side

Site: N6 Left Viewable area = 7,400 wide x 1,000 high. Allow 35mm bleed to each side  
N6 Right Viewable area = 7,415 wide x 1,000 high. Allow 35mm bleed to each side

#### **Hall entrance - totem**

Size: Overall size = 841 wide x 2,704 high  
Viewable area = 811 wide x 2,674 high

## **STATIC, NON-LIT SITES**

### **ALL MEASUREMENTS ARE IN MILLIMETRES**

#### **Hall entrance rear panel**

Size: Overall size = 12,000 wide x 4,000 high  
Viewable area = 12,000 wide x 4,000 high

#### **Hall entrance side panel posters (pair)**

Size: Overall size = 3,000 wide x 6,500 high  
Viewable area = 3,000 wide x 6,500 high

#### **Hall entrance - lower entrance (back only)**

Size: Viewable area = 7,220 wide x 995 high

#### **Boulevard banner**

The artwork should bleed to the outer edges of the poster.  
(EPS artwork template available on FTP – see page 9)

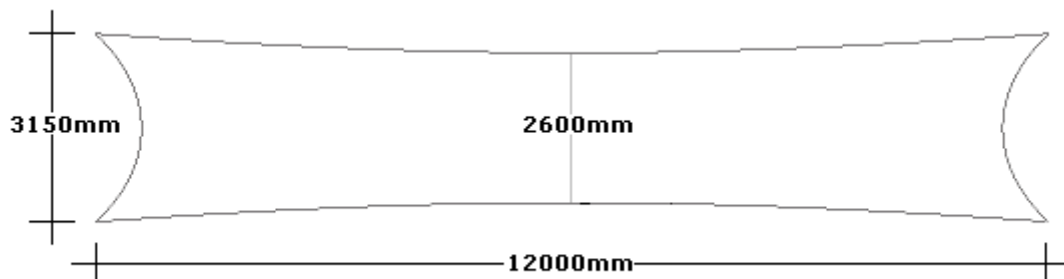

#### **In-hall perimeter banner**

Size: Overall size = 6,100 wide x 2,950 high  
Viewable area = 6,100 wide x 2,950 high

**Please note: these banners will be rigged at a height of 7m from ground to bottom of banner.**

#### **Totem banners**

Size: Overall size = 1,000 wide x 5,000 high  
Viewable area = 1,000 wide x 5,000 high

**Boulevard alcove banner**

The artwork should bleed to the outer edges of the poster.  
(EPS artwork template available on FTP – see page 9)

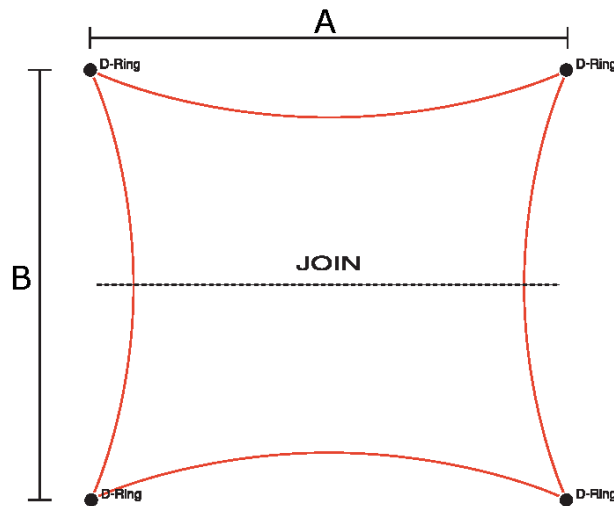

Site: ABN1	Size: Overall & viewable size = 5,590 wide x 5,400 high
Site: ABN2	Size: Overall & viewable size = 5,640 wide x 5,400 high
Site: ABN3	Size: Overall & viewable size = 6,490 wide x 5,440 high
Site: ABN4	Size: Overall & viewable size = 5,640 wide x 5,380 high
Site: ABN5	Size: Overall & viewable size = 5,640 wide x 5,450 high
Site: ABN6	Size: Overall & viewable size = 6,540 wide x 5,500 high
Site: ABS1	Size: Overall & viewable size = 5,630 wide x 5,400 high
Site: ABS2	Size: Overall & viewable size = 6,540 wide x 5,400 high
Site: ABS3	Size: Overall & viewable size = 5,640 wide x 5,400 high
Site: ABS4	Size: Overall & viewable size = 5,640 wide x 5,400 high
Site: ABS5	Size: Overall & viewable size = 6,490 wide x 5,400 high
Site: ABS6	Size: Overall & viewable size = 5,860 wide x 5,470 high
Site: ABS7	Size: Overall & viewable size = 5,790 wide x 5,520 high
Site: ABS8	Size: Overall & viewable size = 6,540 wide x 5,530 high

### Pyramid Welcome banner

Size: Overall & viewable size = 12,000 wide x 2,800 high

### Pyramid shaped banner

The artwork should bleed to the outer edges of the poster.

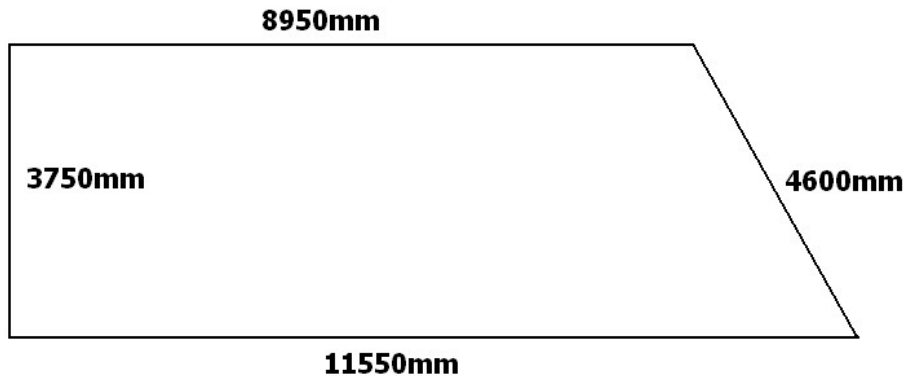

### Taxi drop-off banners

Size: Overall & viewable size = 2,700 wide x 2,500 high

**Please note: these banners will be produced to a mesh material and will allow some light through.**

### A4 Washroom media posters

Size: Overall size = A4 portrait  
Bleed of 15mm all round

### A3 Washroom media posters

Size: Overall size = A3 portrait  
Bleed of 10mm all round

#### Washroom media site breakdown

LOCATION	SIZE	TOTAL NUMBER MALE/FEMALE		LOCATION	SIZE	TOTAL NUMBER MALE/FEMALE
Boulevard B-WC	A3	51 (7)		Platinum Suite - level 3	A4	41 (10)
N2 WC	A3	32 (7)		S3WC	A4	24 (2)
N5 WC	A4	26 (2)		S5WC	A4	24 (2)
N7 WC	A4	25 (2)		S7WC	A4	25 (2)
N9WC	A4	25 (2)		S9WC	A4	25 (2)
N11WC	A4	26 (3)		S11WC	A4	24 (2)
N13WC	A4	25 (2)		S13WC	A4	25 (2)
N15WC	A4	31 (3)		S15WC	A4	24 (2)

The washroom walls are moveable and the ratio of male/female toilets is based on the expected visitor attendance.

Numbers in brackets are posters over urinals. These are included in the total displayed rather than additional.

## PODIUM SITES

### ALL MEASUREMENTS ARE IN MILLIMETRES

#### Podium pennant banner

The artwork should bleed to the outer edges of the poster.

Size: Overall & viewable size = 590 wide x 2,480 high

#### Standard podium flag\*

Size: Overall & viewable size = 1,000 wide x 2,450 high

\* Other sizes are available on request.

## DLR WALKWAY SITES

### ALL MEASUREMENTS ARE IN MILLIMETRES

#### DLR facing banner

Site: DF1 – DF10

Size: Overall & viewable size = 2,775 wide x 1,800 high

Site: DF11 – DF19

Size: Overall & viewable size = 2,250 wide x 1,800 high

#### DLR triangle banner

The artwork should bleed to the outer edges of the poster.

(EPS artwork template available on FTP – see page 9)

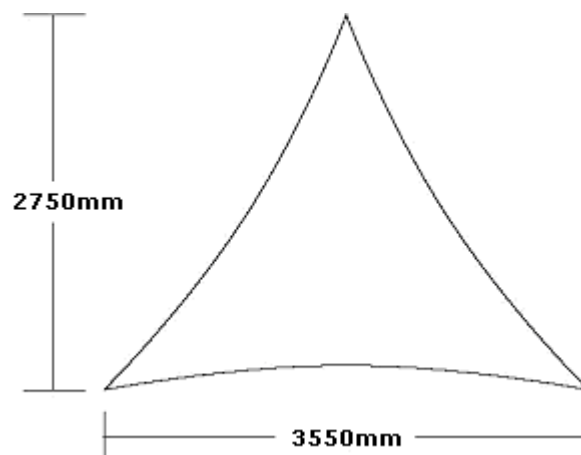

### DLR handrail banner

Size: Overall & viewable size = 3,870 wide x 2,120 high

**Please note: these banners will be produced to a mesh material and will allow some light through.**

### DLR transverse banner

The artwork should bleed to the outer edges of the poster.  
(EPS artwork template available on FTP – see page 9)

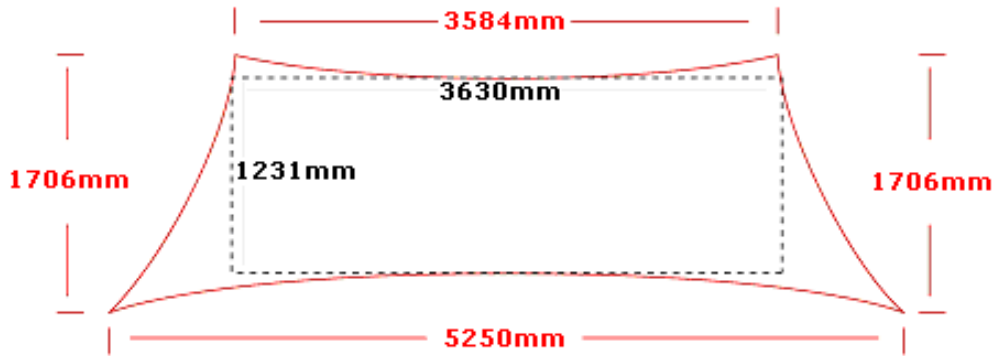

### DLR mini transverse banner

The artwork should bleed to the outer edges of the poster.  
(EPS artwork template available on FTP – see page 9)

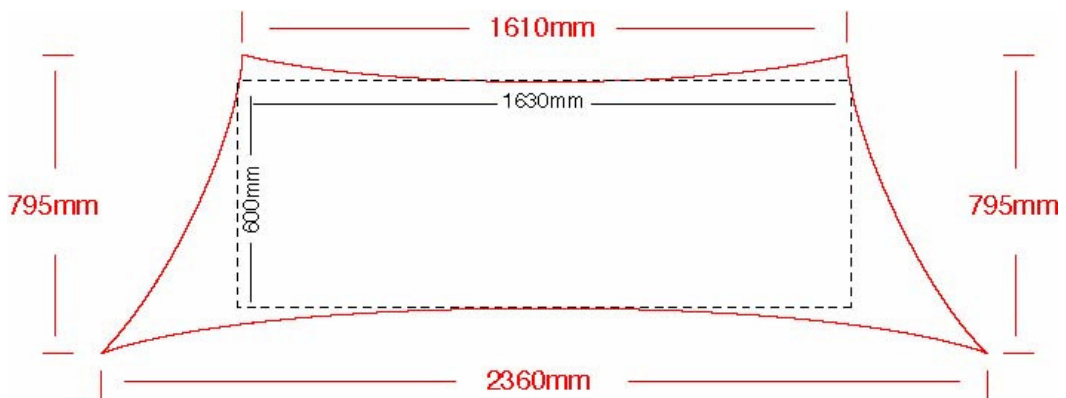

## PLATINUM SUITE ENTRANCE



Please supply A/W as one piece.  
It will be tiled at the print stage

### BESPOKE SIGNAGE

ALL MEASUREMENTS ARE IN MILLIMETRES

#### Corporate pedestals

Size: Overall size = 594 wide x 841 high  
Viewable area = 579 wide x 826 high

#### Welcome boards

Size: Overall size = 1,000 wide x 1,500 high  
Viewable area = 1,000 wide x 1,425 high (from the top to the stand)

#### Sentinels

Size: Overall size = 1,023 wide x 1,528 high  
Viewable area = 975 wide x 1,480 high

### **Suspended corridor signage**

East/West facing

Size: Overall & Viewable size = 500mm wide x 250mm high

S/S Lift facing

Size: Overall & Viewable size = 594mm wide x 841mm high

### **Eatery branding**

Circular tables

Size: Overall & Viewable size = 580mm

Square tables

Size: Overall & Viewable size = 580mm wide x 580mm high

**Note: Eateries have both types of table and therefore artworks for both the square and circular tables should be supplied.**

Seating area surround panels

Size: Overall & Viewable size = 1,865mm wide x 1,000mm high

## **NOTES**

Acceptable programmes: We require final approved artwork in:-

Adobe Indesign CS3, Adobe Illustrator CS3, Adobe Photoshop CS3, Quark Xpress 7, Freehand MX and Coreldraw11 (plus all earlier versions of these programs).

Artwork created in signwriting programs can usually be accepted when exported as .ai or .eps files.

If .pdf documents are being used they must be formatted correctly with NO trim marks or registration marks inside the 'bleed' area.

Fonts: Please ensure all fonts used (both screen and printer fonts) are included. Where possible convert fonts to paths / outlines, particularly for PC generated files. Fonts must be compressed ('stuffed' or 'zipped') prior to dispatch or corruption can occur.

Logos: Any logos should be created in Illustrator or Freehand for best quality.

Photographic Images: For images to be reproduced, without pixilation, a minimum resolution of 45 pixels per inch at full is required. 100ppi at full size produces a very good quality print (but a very large file). Copyright is the responsibility of the client and ExCeL London Invision cannot take any responsibility for this.



One Western Gateway, Royal Victoria Dock, London, E16 1XL

Colours: Our printing system uses a variation of the four colour process system and cannot always match Pantone colours exactly. We will gladly run small colour tests, if required, prior to production (deadlines permitting).

All blacks to be C=40%, M=40%, Y=40% & B=100% (i.e. made up of 4 colours). Please note that failure to comply may result in substandard production, particularly where sites are backlit.

Artwork size: Please ensure that the artwork is sized to the viewable area with any necessary bleed extending out to the overall size.

File size: If possible keep the file size below 500MB uncompressed (particularly if uploading to the FTP site) and keep any file compression to a minimum to preserve final image quality.

Document layout: Artwork should be created in the correct proportion to the final image size, not forgetting any image bleed required. Any placed images and logos must also be included with the artwork.

Shaped banners should have the outline template included in the layout to ensure no elements are lost when the banner is cut to shape.

Outline templates for shaped banners are available for download from our FTP site at:

FTP template details:

Address: <ftp://87.127.29.69>

Username: exceltemplates

Password: excel

Any file manipulation or high resolution scanning required will incur an additional charge.

Artwork supply: Please supply on CD / DVD or upload to FTP.

FTP details:

Address: <ftp://87.127.29.69>

Username: excel2

Password: excelftp

If uploading to the FTP please create a folder in the name of the exhibitor and e-mail confirmation to [ashlealewis@excel-london.co.uk](mailto:ashlealewis@excel-london.co.uk) or [jamesolivier@excel-london.co.uk](mailto:jamesolivier@excel-london.co.uk) once the artwork is fully uploaded.

Proofs: 2 A4 or A3 colour Chromalin laser proofs and any Pantone reference **must** be supplied with all artwork (if uploading to the FTP please send these via 1<sup>st</sup> class post).

Where more than one artwork design is to be used this must be clearly stated, in writing, with the first piece of artwork at time of receipt. Failure to do so may result in a reprint cost for new additional artwork.

Where artworks are to be placed in a specific order, i.e. where more than one of the same site has been purchased, the plan must be submitted with the artwork. Failure to do so may result in a labour cost for repositioning the posters.



One Western Gateway, Royal Victoria Dock, London, E16 1XL

## **Delivery**

All posters / banners etc should be delivered, between 09.00hrs & 16.30hrs Monday to Friday, to:

ExCeL London Invision  
Management Offices  
K Warehouse  
One Western Gateway  
Royal Victoria Dock  
London  
E16 1XL

Where possible deliveries should be made by courier or recorded delivery and signed for by a member of the ExCeL London Invision team to ensure their safe receipt.

## **Lead times**

Artwork and proofs should be received, by ExCeL London Invision, by the date stated on the signed order confirmation or the date agreed, in writing, between the client and the Account Manager. Any artwork received after this time will be subject to a 30% surcharge.

## **Liability**

Where ExCeL London Invision are responsible for the production of graphics, full responsibility will rest with ExCeL London Invision only once **complete approved artwork and a full colour proof have been received from the client within the agreed timeframe.**

## **Storage of all posters and artwork**

All posters, artwork and artwork discs will be disposed of immediately after the last day of tenancy unless prior arrangement for collection has been made and agreed.

Any posters that are stored for collection, by request, but not collected on the appointed collection date will be immediately disposed of and a disposal fee will be payable by the client (as per the signed order confirmation).

## HINTS AND TIPS

ExCeL London is a beautifully sleek, modern venue and bright, bold advertising works really effectively.

Try to avoid white backgrounds or expanses as they can lose impact and be lost against the setting (this is even more true for backlit sites).

Keep messages simple. Too much text will make the viewer lose interest.

Try something quirky, everybody remembers something that makes them smile.

If advertising in more than one site, keep a theme or prominent logo. This will subliminally sink in with the viewer (whether they like it or not).

If advertising at an event and using your stand number on the advertising be sure to check the number with the event organiser before submitting your final artwork (these can change while an event floorplan is still being finalised).

Avoid anything offensive / illegal as this may result in your advertising not being displayed.

Sites printed to mesh (i.e. DLR handrail banners and Taxi drop off banners) will allow light through and therefore darker backgrounds and very bold, simple messages work better.

If you would like to use specific colours but do not have Pantone references, send a sample of the ideal colour you would like with your artwork (for example an existing brochure or a carrier bag) and we will do our best to match it.

Lastly, don't hesitate to contact a member of the Invision team for advice / assistance.

# TERMS AND CONDITIONS

## 1. SCOPE OF CONTRACT

- (a) The following words shall bear the following meanings:
- “**Client**” means the organisation set out in the Order Confirmation, to which ExCeL LI has agreed to provide the Services;
  - “**Deliverables**” means any artwork, posters, banners or other deliverables to be provided by ExCeL LI and set out in the Order Confirmation or otherwise agreed by the parties in writing;
  - “**Display Dates**” means the Run Dates set out in the Order Confirmation or as otherwise agreed by the parties in writing;
  - “**ExCeL LI**” means Opex Exhibition Services Ltd whose registered office is at 30 Old Burlington Street W1S 3NL (Company No. 3973072) trading as “ExCeL London Invision”
  - “**ExCeL London**” means the venue ExCeL London and the land and water surrounding it (or as otherwise specified as the venue on the Order Confirmation);
  - “**Fees**” means the Agreed Cost plus VAT as set out in the Order Confirmation;
  - “**Order Confirmation**” means the document headed “Order Confirmation” setting out details of the services to be provided by ExCeL LI, and signed by both parties;
  - “**Services**” mean the services to be provided by ExCeL LI and set out on the Order Confirmation or otherwise agreed by the parties in writing; and
  - “**Term**” means from the date of signature of this Agreement until the expiry of the Run Dates as set out in the Order Confirmation, or as otherwise agreed by the parties in writing.
- (b) These terms and conditions, together with the Order Confirmation (this “**Agreement**”) shall govern the contact between ExCeL LI and the Client for the provision of the Services and any Deliverables to the exclusion of all other terms and conditions, any oral or written quotation, purchase order, acceptance or acknowledgement of an order by the Client, any specification not set out in this Agreement or any other document (whether or not referred to in this Agreement) or any purported attempt by the Client to impose or incorporate its own terms and conditions.
- (c) All drawings, descriptive matter, specifications, advertising and promotional material issued by ExCeL LI and any descriptions or illustrations contained in ExCeL LI’s catalogues or brochures are issued or published for the sole purpose of giving an approximate idea of the Services and any Deliverables described in them, and shall not form part of this Agreement.
- (d) In this Agreement: (i) any terms in the singular shall include the plural and vice versa; (ii) any reference to a “Clause” means a clause in this Agreement; (iii) the word “including” will not be construed as a term of limitation; and (iv) the headings are included for convenience only and may not be used in construing or interpreting this Agreement.

## 2. PRICES AND QUOTATIONS

- (a) The parties confirm that all quotations provided by ExCeL LI are an invitation to treat and not an offer capable of acceptance. Each order for Services and any Deliverables by the Client shall be deemed to be an offer by the Client to purchase the Services and any Deliverables subject to this Agreement. Any oral orders placed by the client shall be confirmed in writing within 7 days. No such orders placed by the Client shall be deemed to be accepted by ExCeL LI until a written confirmation of the order is sent to the Client.
- (b) Unless previously withdrawn or ExCeL LI specify otherwise in writing, quotations are valid for a period of 30 days only from the date of issue. If, after such a period, ExCeL LI, at the Client’s request, agrees to supply the Services and any Deliverables detailed in such a lapsed quotation this Agreement shall apply thereto.
- (c) Where, at any time before completion of the Services or delivery of the Deliverables to the Client, there is any increase in ExCeL LI’s costs which is due to any:
- Factor outside of ExCeL LI’s reasonable control (including any foreign exchange fluctuation, currency regulation, alteration of duties or significant increase in the costs of labour or materials);
  - delay or additional costs caused by any change in the Client’s instructions, design, specifications or other requirements; and/or
  - negligence or default of the Client (including where the Client gives ExCeL LI inadequate or incorrect information or instructions).
- ExCeL LI shall be entitled, by giving notice to the Client, to increase the amount of the Fees to cover such increases, save that where the Client responds to such notice within 5 working days that it does not wish to pay the increased Fees but instead it wishes to pay all the Fees and any other costs incurred by ExCeL LI in the provision of the Services and any Deliverables to date, then upon such payment this Agreement shall terminate.
- (d) The Fees are exclusive of VAT (and any other applicable sales or purchase tax duty or levy) and the client shall pay all duties taxes or other government charges in respect of the Services and any Deliverables.

## 3. PERFORMANCE

- (a) ExCeL LI will use reasonable endeavours to perform the Services and deliver the Deliverables to the Client by or within any date or period agreed in writing, but such dates or periods are estimates only given in good faith and ExCeL LI will not be liable for any failure to complete or deliver by such dates or within such periods. Time for performance of the Services or delivery of the Deliverables will not be of the essence nor may be made of the essence by notice. If no dates or periods are so specified, performance or delivery will be within a reasonable time.
- (b) Where the Client wishes to change the scope of the Services or any Deliverables, including any dates for performance or delivery it shall put such request in writing to ExCeL LI. ExCeL LI shall confirm in writing whether it will be able to comply with the request and set out any changes to the Fees or dates of performance or delivery. The Client will then have 2 working days to confirm in writing to ExCeL LI whether it wishes to go ahead with the requested change. For the avoidance of doubt, although ExCeL LI will endeavour to comply with

reasonable requests by the Client for such changes, it shall not be under any obligation to do so.

(c) The quantity of a consignment of any Deliverables as recorded by ExCeL LI upon despatch shall be conclusive evidence of the quantity received by the Client on delivery unless the Client can provide conclusive evidence proving to the contrary.

(d) ExCeL LI shall not be liable for any non-provision of any Deliverables (even if caused by its negligence) unless written notice is given to ExCeL LI within 3 working days of the date when those Deliverables would in the ordinary course of events have been received. In any event any liability of ExCeL LI for non-delivery of any Deliverables shall be limited to replacing such Deliverables within a reasonable time or issuing a credit note at the pro rata amount of the Fees against any invoice raised for such Deliverables.

(e) The Deliverables shall be at the risk of the Client from the time of delivery to it. Ownership of the Deliverables shall not pass to the Client until ExCeL LI has received in full (in cash or cleared funds) all Fees due to it in respect of those Deliverables.

(f) Where the Services include the use of any freestanding display units as specified in the Order Confirmation (“**Freestanding Signage**”), the Freestanding Signage shall be delivered to the Client, and the Client must return the Freestanding Signage, upon the applicable dates specified in the Order Confirmation (during ExCeL LI’s normal working hours).

(g) From the time that the Freestanding Signage is delivered to the Client and until it is returned to and accepted by ExCeL LI, the Freestanding Signage is at the risk of the Client, and the Client shall indemnify ExCeL LI from and against any loss or damage caused to the Freestanding Signage during that period, including the cost of any replacement where the Freestanding Signage has been lost, stolen or damaged beyond repair.

(h) Whilst ExCeL LI will endeavour to maintain contact with the Client throughout the period of this Agreement no statements made by any of ExCeL LI’s employees agents or sub-contractors shall be binding on ExCeL LI unless and until it is confirmed in writing by an authorised representative of ExCeL LI.

(i) ExCeL LI shall not be liable to the Client if it is delayed in or prevented from providing any Services and/or Deliverables due to any cause beyond its reasonable control, and should it be so delayed or prevented for 3 months or more, then either party may by written notice to the other, cancel this Agreement without incurring any liability for any resulting loss or damage.

## 4. CLIENT OBLIGATIONS

(a) The Client shall provide ExCeL LI with such assistance, at the Client’s cost, as ExCeL LI may reasonably require in connection with the provision of the Services and any Deliverables.

(b) The Client will be solely responsible for the suitability and accuracy of any specification, design, artwork, graphic or other instruction it provides to ExCeL LI under this Agreement.

(c) The Client will obtain the written approval of ExCeL LI for all posters, banners and other signage (“**Signage**”) to be displayed at any sites or Freestanding Signage at ExCeL London (“**Display Sites**”), prior to the display of such Signage anywhere in ExCeL London. ExCeL LI shall use reasonable endeavours to notify the Client of its approval or non-approval within 7 clear days of receipt by ExCeL LI of any request by the Client for approval of any Signage (to be accompanied by a copy of the Signage) and therefore all such requests for such approval must be received by ExCeL LI at least 10 clear days before the planned start date for the display of any Signage (excluding the date of receipt and the planned start date). Notwithstanding whether such approval has been given, ExCeL LI reserves the right to relocate or remove any Signage from Display Sites, where it deems appropriate due to a conflict of interests with any other tenant at ExCeL London. Where any Signage is so removed (and which has been approved by ExCeL LI in accordance with this Clause) the Client shall be reimbursed on a pro rata basis the applicable Fees for the number of days where the Signage is not on display at ExCeL London.

(d) Where ExCeL LI is not providing the Signage to be displayed on the Display Sites then the Client shall ensure that:

- all Signage shall be delivered on or before the Artwork/Copy due date set out in the Order Confirmation. ExCeL LI may at its discretion accept Signage after such period subject to the payment of an additional charge of 30% of the Fees; and
- ExCeL LI is supplied with adequate and appropriate Signage to fill the Display Sites plus an additional amount to enable ExCeL LI to maintain the Display Sites in good condition as specified by ExCeL LI. A part delivery of Signage shall be deemed to be no delivery at all for the purpose of this Clause 4(d); and
- all Signage complies with the specification sheet, supplied to the Client by ExCeL LI; and
- In relation to the provision of the Signage for the Display Sites it meets any other reasonable requirements of ExCeL LI.

(e) Where ExCeL LI is providing the signage then the Client shall ensure that:

- all specifications, artwork, graphics and other instructions for the Signage are delivered on or before the Artwork/Copy Due Date set out in the Order Confirmation and if no such period is specified at least 14 working days prior to the first Display Date, in such format as ExCeL LI may reasonably request. ExCeL LI may at its discretion accept specifications, artwork, graphics and other instructions for Signage after such period subject to the payment of an additional charge of 30% of the Fees;

and

- It provides its approval or non-approval (with detailed reasons) where requested for any specification, artwork, graphics or Signage within such reasonable period as is stipulated by ExCeL LI.

## 5. INTELLECTUAL PROPERTY RIGHTS

(a) In this Agreement “**Intellectual Property Rights**” shall mean any intellectual property rights (including copyrights, patents, trade marks, service marks, database rights, design rights,

# TERMS AND CONDITIONS

(in each case whether registered, capable or registration or otherwise) and all other similar proprietary rights) as may exist anywhere in the world, for the full duration of such rights (including any extensions or renewals).

(b) The Client warrants that the content of the Signage and/or any specification, designs, artwork, graphics or other materials or instructions it provides, including all Intellectual Property Rights contained therein, are owned by the Client (or its licensors) and shall not infringe any third party rights including any Intellectual Property Rights.

(c) The Client warrants that the Signage;

- Shall comply with all applicable statutory and other legal requirements and the provisions of the British Code of Advertising, Sales Promotion and Direct Marketing; and
- Shall not contain any material that is: defamatory; offensive; unlawful; illegal; fraudulent; offensive; threatening; abusive; harassing; tortuous; indecent; obscene; defamatory; invasive of another's privacy; nor discriminatory whether racially, ethnically, sexually, religiously or otherwise; or which may incite or instruct any person or organisation to undertake such activities; or passes the Client off as, or in which the Client impersonates any person or entity, or otherwise misrepresents itself or its connection with a third party in any way.

(d) ExCeL LI shall be entitled to refuse to display on, or to take down from, the Display Sites any signage which do not comply with Clauses 5(b) and 4(d) above.

(e) The Client shall indemnify, and keep indemnified, ExCeL LI against any and all loss and/or damage it may suffer (including any legal costs) arising due to any breach by the Client of any warranties in Clauses 5(b) and 4(d) above, including any claims by a third party that any Signage infringes its rights including any Intellectual Property Rights

(f) The Client grants to ExCeL LI a royalty free, non-exclusive licence of such of its (or its licensors) Intellectual Property Rights as required by ExCeL LI to perform its obligations under this Agreement, for the duration of this Agreement only.

## 6. CONFIDENTIALITY

(a) Each party shall keep strictly confidential all information concerning the business of the other party (including any trade secrets and Intellectual Property Rights) received from or on behalf of the other party, or otherwise relating to this Agreement, and in each case which is of a secret or confidential nature ("**Confidential information**")

(b) Each party undertakes to only use the other party's Confidential Information for the purposes envisaged by this Agreement, and to only disclose it to such of its employees, agents and sub-contractors who have a reasonable need to know the same, and who are subject to an equivalent obligation of confidentiality.

(c) The obligations of confidence contained in this Clause 6 shall not apply to any Confidential Information that the recipient party can reasonably prove (i) was in the public domain at the time of disclosure; (ii) was lawfully in its possession and was not acquired directly or indirectly from the other party or from a third party under an obligation of confidence (directly or indirectly) to the other party; (iii) is or becomes public knowledge by act or acts other than those of such party; and/or (iv) is required to be disclosed by law.

(d) Neither ExCeL LI nor the Client may (i) use the name of the other either directly or by inference for any purpose whatsoever; or (ii) disclose any information concerning this Agreement, including its existence, in each case without the prior written authority of the other (such consent not to be unreasonably withheld or delayed).

## 7. INDEMNITY

(a) The client indemnifies ExCeL LI from and against any all costs, claims, demands, liabilities, expenses, damages or losses (including any increased costs or expenses, loss of profit, business, revenues or anticipated savings, and/or any special, indirect or consequential damage of any nature, and all interest, penalties and legal and other professional costs and expenses) arising out of or in connection with the Clients negligence, default or breach of this Agreement.

## 8. TERMINATION

(a) This Agreement shall terminate upon the expiry of any Term (unless the parties agree otherwise in writing) and where any Term or period over which the Services or any Deliverables are to be provided is greater than 12 months, then either party may terminate this Agreement on 3 months written notice to the other, such notice to expire no sooner than 12 months after the date of this Agreement.

(b) This Agreement may be terminated for cause by either party in the following circumstances, with immediate effect, from the date of service on the other of written notice if:

- The other party is in breach of any material obligation under this Agreement and if the breach is capable of remedy, that party has failed to remedy such breach within 14 days of receipt of notice so to do: or
- An order is made or a resolution is passed for the winding up of the other party; or (ii) an administrator is appointed to manage the affairs, business and property of the other party; or (iii) a receiver is appointed of any of the other party's assets or undertaking; or (iv) the other party makes any arrangement or composition with its creditors or makes an application to a court of competent jurisdiction for the protection of its creditors in any way; or
- the other party ceases to trade in the UK; or
- there is a change of control of the other party; or
- the other party takes or suffers any similar or analogous action in any jurisdiction in consequence of debt.

(c) Without prejudice to any other of its rights or remedies, upon termination any Fees or other expenses incurred by ExCeL LI up to the date of termination in performing the Services or the provision of any Deliverables (whether or not yet delivered to the Client) will be paid by the Client to ExCeL LI immediately.

(d) Upon termination (howsoever occurring):

- The Clients right to display any Signage upon the Display Sites shall immediately terminate and ExCeL LI shall be entitled to remove all Signage from the Display Sites;
- The Clients right to use any Freestanding Signage terminates, and the Client must immediately return all Freestanding Signage;
- Unless ExCeL LI agree otherwise in writing, any specifications, artwork, graphics or other materials, provided by the Client in digital or electronic format shall be destroyed; and
- Within 1 week of the Client being so notified by ExCeL LI the Client shall arrange for any Signage, and/or any Deliverables which the Client has paid for in full and which are in the custody of ExCeL LI to be collected. Otherwise ExCeL LI shall be entitled, as it sees fit, to either destroy such Deliverables or charge the Client for their storage and insurance and/or return to the Client.
- (subject to any other rights and remedies the Client may have) the Client shall not be entitled to any refund of the Fees and ExCeL LI shall be entitled to be paid any outstanding Fees and/or other expenses incurred by ExCeL LI up to the date of such termination in performing the Services or the provision of any Deliverables (whether or not yet delivered to the Client) which shall be paid by the Client to ExCeL LI immediately.

## 9. PAYMENT

(a) Unless otherwise agreed by ExCeL LI in writing, invoices shall be rendered at ExCeL LI's discretion, which may be upon signature of this Agreement, prior to the commencement of the Services delivery of any Deliverables, or any Display Dates or at intervals during the Term.

(b) Save as provided in Clause 9(c), all Fees shall be paid (without any set-off or other deduction) by the Client upon signature of this Agreement, and where any additional Fees are incurred, within 7 days the applicable invoice is received by the Client, or on the day of receipt where the invoice relates to the provision or display of any Signage at ExCeL London, less than 7 days prior to the applicable Display Dates.

(c) Where the Term is for a period of 6 months or more then all invoices issued by ExCeL LI for any fees or other payments under or in relation to this Agreement shall be paid by the Client (without any set-off or other deduction) within 7 days of receipt, or on the day of receipt where the invoice relates to the provision or display of any Signage at ExCeL London, less than 7 days prior to the applicable Display Dates.

(d) Without prejudice to any other rights of ExCeL LI, interest will be payable on all amounts which are overdue for more than twenty-eight days at 3% above Barclays Bank Plc base rate from time to time calculated from the due date for payment until the date of actual payment.

(e) In the case of any orders placed from outside the UK, unless otherwise agreed in writing by ExCeL LI, all invoices shall be paid in pound sterling direct to ExCeL LI's bank account (the details of which ExCeL LI shall notify the Client), and the Client shall be responsible for all bank transfer costs

(f) Without prejudice to any other rights ExCeL LI may have, ExCeL LI may suspend its performance of the Services and delivery of any Deliverables during any period in which any invoices or other payments due under this Agreement remain overdue including any interest payable thereon.

## 10. MEDIA SALES

(a) In this Clause 10:

- "Media Sales" means the sale to third parties (or the attempt to make such sales) of the right to display, for all or any of the term (or shorter period specified in the Order Confirmation), any Signage at those Display Sites or other media infrastructure the use of which is provided as part of the Services, or any similar services relating to the ExCeL London media infrastructure, in each case as specified in the Order Confirmation, and "Media Sales Rights" means the right to make those Media Sales; and
- "Net Sales Price" means for any Media Sales provided by ExCeL LI as part of the Services (as specified in the Order Confirmation) the amount ExCeL LI receives from a third party in consideration of the right to display any Signage at the applicable Display Sites, during the Term (or shorter period specified in the Order Confirmation), less any costs charged by any third party to pay for other services or deliverables, including any rigging and production of Signage and less any other overheads reasonably incurred by ExCeL LI in providing the Media Sales.

(b) Unless expressly specified in the Order Confirmation ExCeL LI does not grant to the Client any Media Sales Rights.

(c) In no circumstance shall the Client undertake any Media Sales in-house, and it is a condition of ExCeL LI entering into this Agreement (and in particular granting any Media Sales Rights to the Client) that the Client shall only exercise any Media Sales Rights granted to it in accordance with the Order Confirmation, which will specify one (or more) of the following means:

- Media Sales may be included as part of the Services; and/or
- the Client may engage or sub-contract London International Exhibition Centre PLC's approved media sales contractor, Opex Exhibition Services Ltd of 30 Old Burlington Street, London W1S 3NL, to undertake Media Sales.

(d) Where the Order Confirmation specifies that the services provided by ExCeL LI include Media Sales, ExCeL LI shall pay to the Client a commission at the rate notified to the Client in writing (in the Order Confirmation) on the Net Sales Price. Such commission is

# TERMS AND CONDITIONS

payable within 30 days of the close of the event in relation to which the Media Sales were provided.

- (e) Breach of this Clause 10 by the Client shall constitute an irremediable material breach of this Agreement, and without prejudice to any other of its rights or remedies, ExCeL LI shall be entitled to:
- Terminate this Agreement with immediate effect, from the date of service on the Client of written notice to that effect;
  - any Fees and/or other expenses incurred by ExCeL LI up to the date of such termination in performing the Services or the provision of any Deliverables (whether or not yet delivered to the Client) which shall be paid by the Client to ExCeL LI immediately; and/or damages under the indemnity granted by the Client under Clause 7.

## 11. WARRANTIES

- (a) ExCeL LI warrants that (subject to other provisions of this Agreement):
- In providing the Services it will use reasonable skill and use only appropriately qualified staff; and
  - Upon delivery any Deliverables will be reasonably fit for any purpose set out in the Order Confirmation or otherwise agreed in writing by the parties.
- (b) ExCeL LI shall not be liable for a breach of any of the warranties in Clause 11(a) unless the Client gives written notice of the substandard performance of the Services and/or defect in any Deliverables to ExCeL LI within 2 working days of the time when the Client discovers or ought to have discovered such substandard service and/or defect and ExCeL LI is given a reasonable opportunity after receiving such notice to examine any such Deliverables.
- (c) ExCeL LI shall not be liable for a breach of any of the warranties in Clause 11(a) if:
- The Client makes any further use of any such Deliverable after giving such notice; or
  - The applicable sub-standard performance and/or defect arises because the Client failed to follow either ExCeL LI's oral or written instructions, or good trade practice; or
  - The Client alters or repairs any such Deliverables without the prior written consent of ExCeL LI.
- (d) Subject to Clauses 11(b) and 11 (c), if the performance of the Services or any Deliverables do not conform with any of the warranties in Clause 11(a) ExCeL LI shall at its option either: (i) carry out such Services to the correct standard and/or repair or replace such Deliverables (or the defective part); or (ii) refund the price of the applicable Services or Deliverables at the *pro rata* amount of the Fees, provided that, if ExCeL LI so requests, the Client shall return any Deliverables or the part of such Deliverables which is defective to ExCeL LI.
- (e) If ExCeL LI complies with Clause 11(d) it shall have no further liability for a breach of any of the warranties in Clause 11(a) in respect to such Services or Deliverables.
- (f) Any re-supplied Services or repaired or replacement Deliverables under Clause 11(d) will be warranted on these terms and any Deliverables that have been so replaced will belong to ExCeL LI.

## 12. LIABILITY

- (a) The following provisions set out the entire financial liability of ExCeL LI (including any liability for the acts or omissions of its employees, agents and sub-contractors) to the Client in respect of (i) any breach of this Agreement; and (ii) any representation, statement or tortious act or omission including negligence arising under or in connection with the Agreement, the services or any Deliverables.
- (b) All warranties, conditions and other terms implied by statute or common law (save as expressly provided in this Agreement and for the conditions implied by section 12 of the Sale of Goods Act 1979) are, to the fullest extent permitted by law, excluded from this Agreement.
- (c) Nothing in this Agreement shall operate or be construed to operate so as to exclude or restrict the liability of either party for death or personal injury caused by reason of the negligence of such party or for fraudulent misrepresentation.
- (d) Subject to Clause 12(c), ExCeL LI shall have no liability in respect of any loss or damage arising directly or indirectly as a result of ExCeL LI providing the Services and any Deliverables in accordance with any design, specification artwork, graphics or other instructions provided or approved by the Client.
- (e) Subject to Clause 12(c), and notwithstanding anything to the contrary in this Agreement, neither party shall be liable to the other in contract, tort (including negligence or breach of statutory duty) or otherwise, howsoever and whatever the cause thereof for any: (i) increased costs or expenses; (ii) loss of profit, business, revenues or anticipated savings; and/or (iii) special, indirect or consequential damage of any nature whatsoever.
- (f) If, subject to Clause 12 (c) (d) and (e), ExCeL LI should be liable for any non-display or damaged or incorrect display of any Signage then ExCeL LI's liability shall not exceed the *pro rata* amount of the Fees for that display of the Signage on the display Sites for such period of non-display, or damaged or incorrect display.
- (g) Subject to Clauses 12(c) (d) (e) and (f), the total aggregate liability of ExCeL LI to the Client under this agreement and/or in relation to the Services or any Deliverables whether on an indemnity basis or otherwise and whether in contract, tort (including negligence and breach of statutory duty) or otherwise, shall not exceed the total amount of the Fees paid by the Client under this Agreement.
- (h) The Client confirms that on the basis of the financial position and standing of ExCeL LI, the Fees and other amounts payable to ExCeL LI by the Client under this Agreement and other circumstances, the limitations of ExCeL LI's liability to the Client under this Agreement are fair and reasonable and reflect the commercial balance of this Agreement.

- (i) ExCeL LI will only be liable to the Client in respect of any Services or Deliverables not provided in accordance with this Agreement, provided that the Client notifies ExCeL LI in writing as soon as it is reasonably practicable after it becomes aware that such liability may have arisen.

## 13. GENERAL

- (b) **Sub-contracting:** ExCeL LI reserves the right to sub-contract the provision of the whole or part of any Services or any Deliverables required under this Agreement.
- (c) **Assignment:** Neither party may assign, transfer, or otherwise dispose of its rights or obligations under this Agreement without the prior written consent of the other party (such consent not be unreasonably withheld or delayed).
- (d) **Non-Solicitation:** In this Clause "Staff" shall mean any person or people who is/are engaged by ExCeL LI as an employee, agent, consultant, independent contractor or any other form of employment or engagement. During the term of this Agreement and for a period of 12 months thereafter, the Client shall not (except with the prior written consent of ExCeL LI):
- Procure any services or deliverables similar to the Services or Deliverables (or any part thereof), whether directly or indirectly, from any person who within the previous 12 months was a member of staff and was involved in the provision of the Services and/or any Deliverables and/or the management of this Agreement (or in each case any significant part thereof); and/or
  - Solicit and/or engage the services of any person who is a member of Staff and within the previous 12 months was involved in the provision of the Services and/or any Deliverables and/or the management of this Agreement (or in each case any significant part thereof). Without prejudice to any other rights and/or remedies ExCeL LI might have, should the Client solicit and/or engage the services of any member of Staff in breach of this Clause, then it shall pay to ExCeL LI an amount equivalent to 50% of such person's annual gross salary at ExCeL LI at the time of such solicitation and/or engagement to compensate ExCeL LI for its increased Staff costs.
- (e) **Set Off:** Whenever, pursuant to the terms of this Agreement, any sum of money is payable by or recoverable from the Client and due to ExCeL LI then ExCeL LI may deduct or set-off the amount of such sum from any sum then due or which at any time thereafter may become due from ExCeL LI to the Client under this or any other agreement.
- (f) **Variation:** No variation or modification of this Agreement (including any specification of the Services or any Deliverables) shall be valid unless in writing and signed by both parties.
- (g) **No Waiver:** The failure of either party to require the performance of any of the terms of this Agreement or the waiver by either party of any default under this Agreement will not prevent a subsequent enforcement of such term, nor be deemed a waiver of any subsequent breach. The rights and remedies of the parties under this Agreement shall be cumulative and not exclusive of any rights and remedies provided by law.
- (h) **Severability:** Should any provision of this Agreement be declared invalid for any reason, such decision will not affect the validity of any remaining provisions which will remain in force and effect. In any such event, the parties will negotiate in good faith to replace the invalid provision with a provision of equivalent economic effect.
- (i) **Status of the Parties:** Nothing in this Agreement is intended to or shall operate to create a partnership or joint venture of any kind between the parties or to authorise either party to act as agent for the other and neither party shall have authority to act in the name or on behalf of or otherwise bind the other in any way.
- (j) **Third Parties:** Nothing in this Agreement will be construed as conferring any rights or benefits on any person or legal entity who or which is not a party to this Agreement. The Contracts (Rights of a Third Parties) Act 1999 and any other legislation in any jurisdiction applicable to this Agreement that confers contractual rights on third parties, is hereby excluded to the fullest extent permitted by law.
- (k) **Notices:** Any notices should be in writing and should be made by hand, by recorded delivery or by email or fax (for notices sent by email a supporting physical copy must be sent on the same day by post) to such numbers as the parties may specify from time to time. Notices sent by hand by fax or by recorded delivery post will be treated as having been received on the working day after the day upon which they were sent. Proof of fax transmission and of successful far-end receipt must be kept. Emails will only be treated as having been received when a non-automated response is obtained from the email recipient.
- (l) **Entire Agreement:** This Agreement constitutes the entire agreement and supersedes all previous verbal or written proposals and agreements between the parties relating to the Services. Except as expressly stated in writing in this Agreement, neither party has relied upon any statement or representation made by the other in agreeing to enter into this Agreement.
- (m) **Governing Law:** This Agreement, all matters regarding the interpretation or enforcement of it, and any other matters or disputes arising in connection with it or its subject matter, including the Services and any Deliverables, is governed by English Law and the parties hereby submit to the exclusive jurisdiction of the English courts.